

SUSSEX INDUSTRIAL HISTORY



**Brighton Brewers - Rottingdean Mill
Turnpikes to Horsham
Cowfold and Henfield Turnpike (Part 2)
CVA at Coombe Road, Brighton**

ISSUE 38

Price £4.25

2008

SUSSEX INDUSTRIAL HISTORY



Journal of the Sussex Industrial Archaeology Society

THIRTY-EIGHT

2008

CONTENTS

		Page
THE BREWERS OF THE BRIGHTON AREA	Peter Holtham	2
ROTTINGDEAN MILL	Ron Martin	9
TURNPIKES TO HORSHAM	Brian Austen	17
THE COWFOLD AND HENFIELD TURNPIKE TRUST 1771-1877		
Part 2—The Branch Road and Later	John D. R. Townsend	30
CVA AT COOMBE ROAD, BRIGHTON	Peter Groves	38
Digitisation of <i>Sussex Industrial History</i>		39
Publications		40

Cover illustration—Rottingdean Windmill (Ron Martin)

Edited by Dr. Brian Austen, 1 Mercedes Cottages, St. John's Road, Haywards Heath, West Sussex RH16 4EH (Tel.01444 413845). Design and layout by Alan Durden. The Editor would be interested to hear from prospective contributors of articles of any length. Shorter notices can be included in the Society's *Newsletter* which is issued four times a year.

The annual subscription to the Sussex Industrial Archaeology Society is £10 payable on 1 April. Life membership is available at fifteen times the annual subscription. Members are entitled to copies of the *Sussex Industrial History* and the *Newsletters* without further charge.

Membership enquiries to the Hon. Secretary, R.G. Martin, 42 Falmer Avenue, Saltdean, Brighton BN2 8FG (Tel. 01273 271330). Website: www.sussexias.co.uk

ISSN 0263 5151

© SIAS on behalf of the contributors

THE BREWERS OF THE BRIGHTON AREA

Peter Holtham

Brighton's last historic brewery, Tamplin's Phoenix brewery, closed in 1973. Listed below, alphabetically under streets, is a comprehensive list of all brewers known to have operated in the Brighton & Hove area up until World War II. Sadly there are very few remains, but where some do exist these are marked [VR] followed by a map reference. Since the terms "brewer" and "publican" are often synonymous, it is possible that some entries may relate to pubs that did not in fact brew their own beer. Sometimes the name is that of the owner rather than the operator. Several small post-war independent concerns and brew-pubs have since come (and gone) and these will possibly be the subject of a later article.

Sources

The main source of the information has been the Brighton trade directories. This has been supplemented by town rate books, where available, and the author's observations.

Acknowledgements

I am grateful for information either supplied or confirmed by Graham Holter and Roger Bristow.

Explanations of the text

Since directories are not always available for every year the symbols "-" and "+" have been used to mean "before" and "after" the stated date. "Taken over by" has often been abbreviated to "t.o.b."

The writer would be pleased to provide additional information on any of these entries and to receive further information if available.

BRIGHTON

*The Crown Brewery (I), Malt & Hop Brewery
7, then 8 & 3, Albion Hill*

-1854+ Thompson, Edward Lawson, "Crown Brewery" (at No. 7)

-1863/72 Austin, D "Malt & Hop Brewery",
(at No. 8)

-1875 Wm, "The Malt & Hop Brewery"
(at No. 3)

The Albion Brewery, 9/10, Albion Street

-1854 Feb. Cheeseman, Robert Edward?

1854+ Clarke, William

-1856/68 Keeping, John

1869 Baker, B (a tenant)

1870/74 Keeping, John (M.P. Castle a tenant?)

1874/80 Keeping & Co. (M.P. Castle a tenant?)

1880/92 Castle, Marcellus Purnell

1892 (Tamplins & Co.) Brewing ceased, premises retained by Tamplins as stores.

1982 demolished

The Bush Brewery, Arundel Road

c1825/Feb. 1827 Bush, William

The Anchor Brewery, Bartholomews

c1789/1830 Robins, Ebenezer

1831 brewing transferred to Hove

The Black Lion Brewery, 14, Black Lion Street

[VR as rebuilt at TQ 310040] (fig.1)

Not to be confused with the once nearby Black Lion Inn of Deryk Carver who brewed there in the 16th century. For further information see *Sussex Industrial History* issue No. 22.



Fig. 1 Black Lion Brewery (Photo: author)

-1733?/1770+ Hicks, William (died 1765, son John inherited?)
 1770+/1823 Chapman, William (died 1823).
 1823/1828+ Chapman, William exors. of.
 -1832/50+ Davis, Benjamin
 -1852+ Chapmans Brewery
 -1854+ Hales, John & Fellows, Frederick
 -1856+ Tombs & Hale
 -1859/61+ Black Lion Brewery, Hale & Fellows
 -1863/74 Black Lion Brewery, Hale & Oxenham
 1875/77 Black Lion Brewery, Hale & Baily
 1878/-84 Black Lion Brewery, Charles Chedwode Baily trading as Chapman & Co.
 1884/1901 Black Lion Brewery, Chapman & Co. C C Baily
 1901/11 (Rock Brewery Brighton Ltd)
 1912 January sold
 -1913/67+ (Fremlins Brothers).
 1968 premises sold by auction and demolished
 A reproduction of the original brewery has been erected on part of the site.

The Bond Street Brewery, 18, Bond Street
 [VR at TQ 310043]

c1822/26 Pollard, Theophilus
 c1826/38 Yeates, John and Graveley, Joseph

11, Brunswick Place North

-1824+ Ellis, David
 -1839+ Greene, Isaac

The Queens Park Brewery, 57, Carlton Hill

1869/76 Bird, Thomas

The Derbyshire Brewery, 80, Carlton Street

-1863/66 Yeoman, J.

The Carlton Brewery, 82, then 93, Carlton Street/Hill

-26.5.1823 Hall, Morris
 -1828+ Townsend, Elkenton (Carlton Brewery)
 -1832+ Townsend & Co.,
 -1839/40+ Michell, William
 -1843/46+ Keeping, Oliver
 -1850+ Keeping & Cheesman
 -1852 Cheesman, Thomas & Co.
 1852/66 White, George
 1867/72 Tourle, James
 1873/74 Warde, Ambrose & Thompson, William
 (19.7.1876 sold to J.M. & F.J. Kidd, of the Cannon Brewery)

The Castle Brewery, 31/2, Castle Street,

-1839/43+ Jackson, Thomas
 -1846+ Palmer, Edward
 -1850/51 Meane, John & William.
 -1852+ Berry, Thomas
 -1853/1906 Ashby & Co.
 25.6.1906 Taken over by Smithers & Sons Ltd
 Premises put to other uses and survived until c1991

St Nicholas Brewery, 10, Centurion Street

1867/70 Whitaker, Benjamin

The Chapel Street Brewery, 33 then 30, Chapel Street

-1854+ Kirkpatrick, Robert Read
 1864/65 Embling, A.J. & Co.
 1866/69 Embling, A.J. T/a The Chapel Street Brewery
 1874 Became H & G Simmonds' – wine & spirit store and survived under other uses until demolition in 1992

The Star Brewery, 37/8, Church Street

-1854/63 Marner, John
 1864/73 Gould, & Son
 1873/76 Warde, Ambrose & Thompson, William
 19.7.1876 property assigned to J M & F J Kidd of the Cannon Brewery

at Ditchling Road

-1843+ Dunk, David

Edward Street

-1865+ Newman, H

The Sussex Brewery, 44, Essex Street

1825 "newly built" (Marshall, I. query whether he actually brewed?)
 -1827 Whymark, David
 -1832/3+ Smithers, W.S.
 -1834+ Smithers, H

37 or 38, Frederick Place

-1854 Feb. Molton, John (No. 37)
 1854 July Tennant, Matthew (No. 38)

The Eagle Brewery, 39 & 40, George Street

-1822+ Lower, John & Jesse
 -1824+ Slater & Co.
 -1828+ Slater, Edw Thomas
 -1832/3+ Bewsher, William Noble.

-1834+ Becket, Charles
 -1839/40 Durrant, William
 -1843/52+ Whichelo, John
 -1854 Horn, Henry
 1854+ Griffith, Chas

The Gloucester Brewery, 121/2, Gloucester Road

-1856/61+ Dowling, John (Ginger Beer Mfr)
 -1863/79 Dowling, John
 1880/97 Dowling, Henry
 1898 Muggeridge, H (may not have actually brewed?)
 1905 Pub sold to Tamplins
 c1973 Demolished

7/9, Henry Street

1864/69 Holford, George
 1870/71 Sims, William

The Suffolk Brewery, later The Swan Brewery, 32, Henry Street

1868 Spink, Elisha & Co (Suffolk Steam Bry)
 1869 Chard, William (Swan Brewery)
 1870/71 Eastaugh, H.J. & Co. (Swan Brewery)
 1872 Pubs acquired by Kidd & Hottblack
 1874 became ginger beer manufactory

The Crown Brewery (II), 28 then 17/18, Jubilee Street

-1844 Shar(w)ood, Charles
 -1854 & 1863/67 Sinden, Edmund John
 1868/84 Buckwell, Alfred

58, King Street

-1824 Sandell, John
 1824+ Piercy, H
 -1832+ Sharp, Isaac
 -1839+ Green & Mills

46, Lavender Street

-1828+ Pitcher, William (retail brewer)

Little Castle Street

-1839+ Boxall, Jonathan

The Viaduct Brewery, later The Amber Ale Brewery, 72, London Road

-1837/43+ Shuckard, George
 -1845/52 Hardwick, William Hamshar
 (The Viaduct Brewery)
 1852/88 Longhurst, Henry (The Amber Ale Brewery)

1888 September - Henry Longhurst died
 1888/98 Henry Braddock Longhurst
 1898 (pubs taken over by Abbey & Son of Brighton)

4.10.1899 R Fry & Co. Ltd mineral water manufacturers

1901 Premises demolished for road widening. The malthouse became the Duke of York's Cinema.

The Atlas Brewery, 112, London Road

-1848/50+ Bisshop, James & Edward
 (at Marshalls Row)
 -1852+ Greenfield, William (Marshalls Row)
 -1854 Hooker, William (The Atlas Brewery)

at 119, London Road

-1839/40+ Tibbs, George

38, Marine Parade

-1845/46+ Jackson, Thomas

"Blacksmiths Arms", 7, Marlborough Street

-1845/46+ Coates, Frederick

56, Middle Street

-1744/57+ Masters, Richard & Benjamin(?)
 -1784+ Lucas, Elizabeth
 -1793/1805 Lucas, John (and Hobden, Henry?)

The Globe Brewery, Mighell Street

-1824+ (proprietor unknown?)
 1825 Offered for sale

The College Brewery, 13 then 15, Montague Place

-1854+ North & Marshal
 1855/71 Marshall, Charles
 1872/79 Hilder & Body
 1880/81 Body, J.A.
 1882/94 Hodges & Ritchie
 1895/1900 Willett, William & Son
 1901 taken over by Rock Brewery Brighton Ltd and used as a store by them and later by Kemp Town Brewery. Demolished in 1988.

The North Street Brewery, 89/90, North Street

For further information see SIH issue No. 22
 -1822+ Chandler, Charles & Richard
 -1824/26 Chandler, R (died 1826)
 1826/33+ Chandler, Eliza
 -1837/59+ Smithers, Henry & Isaacson, Thomas
 -1861+ Smithers & Son
 -1863 The Brighton Brewery Co.

1864/1902+ Smithers & Son
 -1904/05 Smithers & Sons
 1906/20 Smithers & Sons Ltd
 1920 November - brewing transferred to
 The Portslade Brewery
 c1923 The Brighton brew house was sold
 1984 Brighton brew house demolished

104, North Street
 1799 Morling, John
 1800/+ Morling, Philip

Oxford Street
 -1828+ Lloyd, Jas. Retail brewer

Princes Place
 -1800+ Kirby, John
 -1805+ Edward & Co. (spruce beer brewery)

Ridges Brewery, 71 then 98, Queens Road
 -1839/61+ Ridge, James (mineral water mfr)
 -1863/72 Ridge & Sons (mineral water mfrs)
 1873/83 James Ridge & Sons (mineral water mfrs
 & family brewers)
 1884/5 Ridge & Burroughs, (mineral water mfrs
 & family brewers)

The Regent Brewery, 52/3, Regent Street
 -1852+ Keeping, John
 -1854+ Keeping, John & Bradley, Robert

*The Royal Colonade Brewery, (office) 5, New Road
 (brewery) 30, Richmond Buildings*
 -1831 Wigney, George Adolphus
 31.12.1831/1834+ Biley, William & Co.

The Cannon Brewery, 16, Russell Street,
 For further information see SIH issue No. 22
 c1821/70 Barnett, John
 1871/84 Kidd, John Mills & Frederick James
 1885/97 Kidd, John Mills and Hotblack,
 Herbert Arthur. -T/A Kidd & Hotblack.
 1897/1900 Hotblack, Herbert Arthur
 T/A Kidd & Hotblack
 1900/1906 Hotblack, Frederick Mills
 T/A Kidd & Hotblack
 1906/26 Hotblack, Frederick Mills
 T/A Kidd & Hotblack Ltd
 1927/64 Tamplin & Sons beer depot
 c1966 demolished

53, St Georges Road
 -1854+ Proctor, Robert Shawe

The Rock Brewery, 61, St James's Street
 For further information see SIH issue No. 22
 1809 "newly erected"
 -1822+ Herriot & Palmer
 -1824+ Palmer, Richard
 -1828/32+ Rowe & O'Connor
 -1839/40+ O'Connor, Elizabeth
 -1843/45 Horne, John
 1846/52 Griffith & Co and Sewell, Isaac.
 (Griffith, John Stonehouse murdered 6.2.49)
 1853/54+ Thrupp & Co.,
 -1856/61+ Catt, W & Co.,
 -1863/1900+ Willett, Wm & Son.
 22.4.1901/1927 Rock Brewery Brighton Ltd
 1928 Feb./48+ Brewing ceased,
 t.o.b. Portsmouth & Brighton United
 Breweries Ltd and used as depot)
 1978 Premises demolished

*The Kemp Town Brewery, formerly the Bristol
 Brewery, 6, Seymour Street,*
 For further information see SIH issue No. 22
 -1839/52+ Hallett, William (Bristol Brewery)
 -1854/90 Hallett & Abbey (Bristol Brewery)
 1891/99 Abbey & Son (Bristol Brewery)
 1900/07 Abbey & Sons (Bristol Brewery)
 1908/20 Abbey & Sons (Kemp Town Brewery)
 1921/33 The Kemp Town Brewery
 1933 March/64 The Kemp Town Brewery
 (Brighton) Ltd
 1954 Taken over by Charrington & Co Ltd
 31.3.1964 last brew.
 c1970 demolished

The Ship Street Brewery, 21, Ship Street
 1757/99 Tidy, Richard
 -1784/93+ Whichelo, Richard (tenant?)
 -1799/1805 Whichelo, John (bankrupt 1805)
 1805+ Wigney, William
 -1822/24+ Messrs Wigney
 -1828/36 Wigney, Wm & Sons
 1836/47 Wigney, William & George
 1847/50(October) Wigney, William
 1850/54+ Vallance & Catt
 1892 premises finally by Charles W Catt

65, Ship Street
 1861/66 Bird, Thomas

The Bedford Brewery, 18, then 28, Sillwood Street

- 1839/40+ Pocock, John
- 1843/44 Hawkes, William Robert
- 1844/45 Pocock, John
- 1846/48+ Keeping, John
- 1849/50 Keeping & Cheesman
- 1851/2+ Cheesman, Thomas & Co.
- 1853+ Ashby, William Grover & Silvanus
- 1856/1906 Ashby & Co.
- 25.6.1906 conveyed to Smithers & Sons Ltd., of the North Street Brewery. Premises became the Bedford Garage and survived until 1981

The Preston Brewery, South Road, Preston Village

- 1801 (when sold by Bartholomew? Smithers) and later:-
- 1852+ Brook, James & Co.
- 1855+ Brook, J & C and Ingold
- 1858/73 Brook, J & Ingold, W
- 1873/84 Brook, Joseph
- 1886+ Chandler, William
- 1888/95+ Brook, J & Co.

The Station Brewery, 10, then 8, Station Street

- 1864/79 Carter, W

The Temple Brewery, 21 then 24, Temple Street,

[VR house only at TQ 301045] Brewhouse was at rear

- 1854 Hussey, Edward King
- 1854/6+ Goble George
- 1859/61+ Stenning, Wm
- 1863/5 Hussey, Edw K
- 1866 Hussey, Ann
- 1867/9 Long, D.W.M.
- 1870/1 Fraser, W
- 1872/3 Fraser & Co,
- 1873/4 Hayes & Sutton
- 1875/6 Fraser & Dudney
- 1877 Pennikett, J
- 1878 Goddard, Edmund
- 1879 Fraser, E

49, Upper Bedford Street

- 1832+ Craig, John
- 1834+ Fierner, Thomas
- 1844+ Craig, William James

The Vine Street Brewery, 24/5, Vine Street (fig.2)

[VR at TQ 312046]

- 1887/90 Carter, W— premises survive, having been put to other uses.



Fig.2 Vine Street Brewery (Photo: author)

The Phoenix Brewery Waterloo Street North, (office) 1/3, Richmond Terrace (fig.3)

For further information see SIH issue No. 32 [VR only the former counting house remains at TQ 315049]

- 1821 Founded
- 1821/24+ Tamplin, Richard
- 1828/43+ Tamplin, Richard & Son
- 1845/49 Tamplin, Richard and Henry Pagden (Richard died 1849)
- 1849/63 Tamplin, Henry Pagden
- 1863/67 Tamplin, Henry Pagden & William Cloves
- 1867/89 Tamplin, William Cloves
- 1889 May/1962 Tamplin & Sons Brewery Brighton Ltd
- 1953 Taken over by Watney Mann Ltd
- 13.2.1962/1969 Tamplins Brewery Ltd
- 1969/73 Watney Mann (London & Home Counties) Ltd
- 28.11.1973 Last brew
- c1980 Brewery demolished but the premises were retained as a depot until 1991

The West Street Brewery, 8, West Street

For further information see SIH issue 22

- c1767/70 Grover, Isaac
- c1770/1789 Grover, Isaac and Killick, Robert Bucknoll, James
- 1790/97 Killick, Robert and Vallance, John Phillip & James
- 1798/1805+ Vallance & Sons
- 1822+ Vallance, John & Edmund
- 1824+ Vallance Sons
- 1828+ Vallance, James & Sons
- 1832/49 Vallance & Catt



Fig.3 Brighton, Tamplins Brewery Office (Photo: author)

1849/89 Vallance & Catt & Co.
 1890/95 Vallance & Catt & Co. The West Street
 Brewery
 1895 Sept/1913 The West Street Brewery Co Ltd
 1913/18 The West Street Brewery amalgamated
 with Smithers & Sons Ltd

at 19, West Street

-1829 Dumbrell, George (sold 1829)

16, Western Street

-1834+ Anscombe, Joseph(?)

-1839+ Jones, Elizabeth

-1843+ Jones Henry

HOVE

*The Brighton (Steam) Brewery, 26A, Osborne
 Street*

1852/69 Gallard, George (The Brighton Steam
 Brewery)

1870/1900 Weeks, Richard Carey
 (The Brighton Brewery)

1900/01 (12 Pubs t.o.b. Tamplin & Sons Brewery

Brighton Ltd)

1902 premises sold and demolished.

*Robins Brewery, The Anchor Brewery, 57, Waterloo
 Street*

1789 business founded (in Bartholomews,
 Brighton until c1831)

-1832/42 Robins, Ebenezer

1842/94 Robins, Ebenezer (William) & Son

23.3.1894/1924 Robins, E & Son Ltd

c30.1.1928 (or possibly earlier) brewing ceased,
 continued as Findlater Mackie & Co – beer
 wine & spirit merchants with a bonded
 warehouse in Brighton. The pubs were
 bought by The Tamplins and The Kemp
 Town Brewery.

Botanical Brewer, 170, Westbourne Street,

1908/11 Brumpton, William Thomas

PORTSLADE

*The Southdown Brewery, The Portslade Brewery,
 High Street [VR at TQ 254063] (fig.4)*

For further information see *SIH* issue 25

1849 founded by John Dudney

1849/69 Dudney, John

1869/84 Dudney John & Sons

1884/1919 Mews, Walter & Herbert

Dudney, William T/A Dudney & Sons & Co.

* 1919 Business sold to Kemp Town Brewery
 of Brighton who sold the brewery
 building on to Smithers & Sons Ltd of
 Brighton together with some of the pubs.

1920/1929 Smithers enlarged the brewery and
 closed their Brighton plant.

1929 Company shares purchased by Tamplin &
 Sons Brewery Ltd of Brighton

21.8.1930 Brewing ceased

20.3.1931 Business conveyed to Tamplin &
 Son's Brewery Brighton Ltd

1938+ Premises survive having been put to a
 variety of other uses.

In a part of the above former brewery building:-

1931/-36 Stanford & Co.

-1936/38 The Portslade Brewery Co.

Lower Portslade (location?)

-1858+ Still, Richard (brewer & baker)

Corrections and Additions

Research is on-going. From feed-back I have received following the previous articles I would like to make the following corrections and additions:-

SIH Issue No. 34

Crawley, Station Brewery

To read:-

- 1869/1873 Holder, Henry
- 1874/1907 Ockenden, George & Son

Crawley, New Road Brewery

To read:-

- 1866/70+ Ockenden, Charles
- 1874/1907 Ockenden, George & Son

Delete the reference to New Town, Ifield

East Grinstead: Michael Leppard who originally brought much of this information to my attention suggests that:

Re. *The Sussex Brewery and the East Grinstead Brewery, 32, North End* – these were the same place, Edmund Wise being there from late 1862,

and

“*The Green Dragon*” was at No. 13 High Street, now a Prezzo restaurant

SIH Issue No. 36

Asburnham Brewery:

Address should be *Brownbread Street*

Battle Brewery:

Leney, Walter dates are thought to be 1849/63

Uckfield Brewery:

Built by *John Whapham* 1795



Fig.4 Portslade Brewery (Photo: author)

NOTE

Sussex Industrial History 37 (2007)

This issue contained an article on the Manor Mill at Poyning's. The author of this article was Richard Howell.

ROTTINGDEAN MILL

Guy Blythman and Ron Martin

Rottingdean Mill is located on Beacon Hill at TQ 365024, 160 m north of the South Coast Road, A259. It is an octagonal four storey smock mill on a substantial single storey base of flint rubble, rendered and tarred externally with brick lacing courses and birdsmouth angles. In the base there were two doors, facing east and west, with brick quoins. After the mill ceased working these were infilled with herringbone brickwork, the eastern one only partly so, the remaining space being filled with a steel door, which currently provides access to the mill. Inside, square openings in the walls and odd bits of timber projecting from the brickwork, suggest that the base has been heightened at some time during the mill's working life, the floor levels being changed accordingly. The transition from a low structure with common sails that could be reefed from the ground to a taller one with self-adjusting patent sails meant that no stage was ever required.

The superstructure is mainly of oak and has been strengthened by the erection of a steel framework internally, which somewhat restricts the internal space. The cap is of the Kentish variety with the

shape, more or less, of the roof of a post mill. Like many caps of this type in Sussex it is not quite wide enough to cover the cap circle and a rounded pannier is necessary on both sides to prevent ingress of rainwater through the resulting gap. Beneath the cap circle is a ring of vertical boarding protecting the rack, with a break in it at the rear, for the worm to engage with the wooden teeth. The fanstage, the guide pole of the striking chain and the striking wheel have all gone and the diagonal timbers of the fantail cradle have been cut off just beyond the rear gable of the cap. The iron winding worm is still extant, but lying on the ground floor, together with various other pieces of unidentified metalwork.

The upright shaft is very long and is supported just below the first floor by a wooden hurst frame, the vertical posts of which terminate in a horizontal beam which is sunk 200 mm (8") below floor level to give the whole assembly rigidity and stability. The shaft is circular for the bottom 215 mm (9"), octagonal where the great spur wheel and the crown wheel are mounted, but otherwise 16-sided, with some rather nice stops in the form of rounded aprons.

The great spur wheel is iron, with wooden cogs, most of which are still extant. At some time, one section of the rim had broken off and been replaced with a timber block, braced to the adjacent spokes with iron straps. The clearance between the wheel and the upright posts of the hurst frame is very slight and one of the posts has been partly cut away to make a channel for it to turn in. The bridge trees and brayers of the tentering gear remain but the governors and steelyards have gone.

On the stone floor there are no remains of the stones or stone casing although their location can be determined by reference to recesses in some of the floor beams. One peak and one French burr stone is located, unmounted, in the ground storey, leaning against the wall. The crown wheel, from which auxiliary machinery would have been driven, is extant, with only two of the teeth now remaining. This is of primitive design being an upturned face gear in the form of an almost solid wooden disc made up of four sections each carried by a short arm which is little more than a tenon. It is therefore old, going back to the early 19th century. The Industrial Revolution had not really begun to bite away from the areas where it first started, such as the North and Midlands. Thus many windmills were still being built with wooden machinery of relatively basic



design. Usually they were modernised to some extent during the course of the century as iron gears and shafts, though still fairly expensive, gradually became cheaper and more widely available. At Rottingdean some parts such as the great spur wheel and windshaft were renewed in iron while others were left as a cost-cutting measure. The currently dismantled wallower is of the same type and design as the crown wheel, with one of the tenons still in place.

Suspended just above the crown wheel, on hangers from the beams in the floor above, is a wooden frame carrying a hinged lever with a circular hole in it through which would have passed a horizontal shaft ending in a pinion whose teeth would have meshed with the cogs on the wheel. There is a lever for moving the shaft in and out of gear when pulled by a rope or chain. The timber in which the other end of the shaft was mounted, presumably in a groove, has been replaced during renovations. The shaft itself and the machine it drove have long since vanished.

The bin floor is completely empty, the bins having been removed, although some of the outer walls are lined with timber boarding.

The brake wheel is a fine wooden clasp-arm type mounted on a relatively short cast iron windshaft which tapers markedly behind the wheel. To the rear of the tail bearing, part of the striking gear may be seen. The brake and brake lever remain.

History¹

The mill was probably built in 1802, the first owner being Thomas Beard, whose initials "TB 1802" have been carved on one of the original timbers. An article in the local paper² describes the finding of a skeleton during the digging of the foundations of a windmill and refers to the "master, Mr. Beard", so it is more than likely that this is the mill that is being referred to. The mill ground corn for the village until 1881, when the then miller, George Nicholls, retired and the mill ceased to function. Later it became derelict, losing its sweeps and fantail. In 1922 the village realised that it was likely to lose its mill, and a Parish Meeting was convened and raised the £400 needed to repair it, when much of the machinery was removed and the doors bricked up. A 99-year lease was then granted by the owner, the Marquess of Abergavenny, to four trustees from the village, who "undertook not to alter or detract from the picturesque appearance of the mill and to preserve

the same as an object of interest to the inhabitants and visitors to Rottingdean". The lease was subsequently transferred to Brighton Borough Council, now Brighton and Hove City Council, and expires in 2021, when the responsibility for the Mill reverts to the City Council.

In 1929 the Mill was re-tarred and minor repairs were carried out, and in 1935, thanks to the generosity of a Mr. Yapp, the mill was made waterproof and a new set of sweeps fitted. The Rottingdean Preservation Society was formed in 1960, and the trusteeship of the Mill was vested in members of the Society. A local resident, William Heinemann, is believed to have been inspired by the mill for the colophon which is now used on books published by the Heinemann Press, although the design of the colophon is nothing like Rottingdean Mill.

In the 1960s various repairs were carried out, and in 1969 as the result of a survey carried out by Robert Gregory, a respected mill expert, a steel frame was erected by Ernest Hole, at a cost of £3,500, to stop the structure twisting and eventually collapsing. This work was done without any financial help from Brighton Borough Council but with a large bequest to the Rottingdean Preservation Society from the late Mr. R. A. Caton. In the 1970s further repairs and renovations were carried out on a regular basis, two of the sweeps were dismantled and virtually rebuilt on the advice of Frank Gregory.

During the 1980s and 1990s further extensive repairs were carried out by Paul Rigden on the advice of Vincent Pargeter, the Society for the Protection of Ancient Building's millwright. Three cant posts have been replaced and the intermediate framing rebuilt, the remaining five cant posts reinforced and the steel frame extended.

Recently, a new staircase was inserted between the ground floor and first floor to provide easier access to the public and a new set of stocks and sweeps fitted. This was made possible as a result of the generous support of the Heritage Lottery Fund, who awarded the Society a grant of £41,800. The mill is now regularly opened to the public.

References

1. Rottingdean Preservation Society, *The Story of Rottingdean Windmill*
2. *Sussex Weekly Advertiser*, 7 June 1802

ROTTINGDEAN WINDMILL

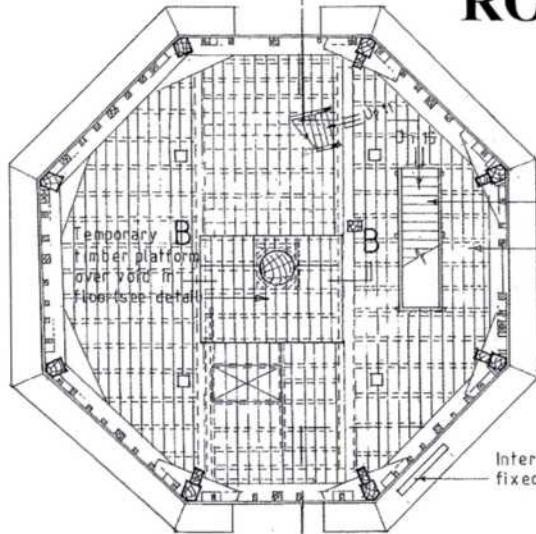
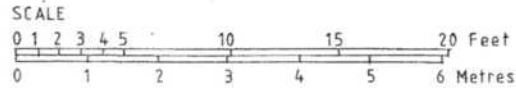

FIRST FLOOR PLAN

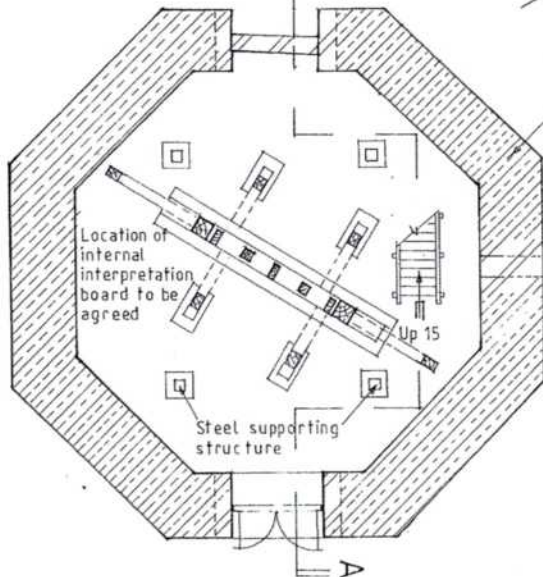

GROUND FLOOR PLAN

N.B Section through cap not aligned with Section A-A

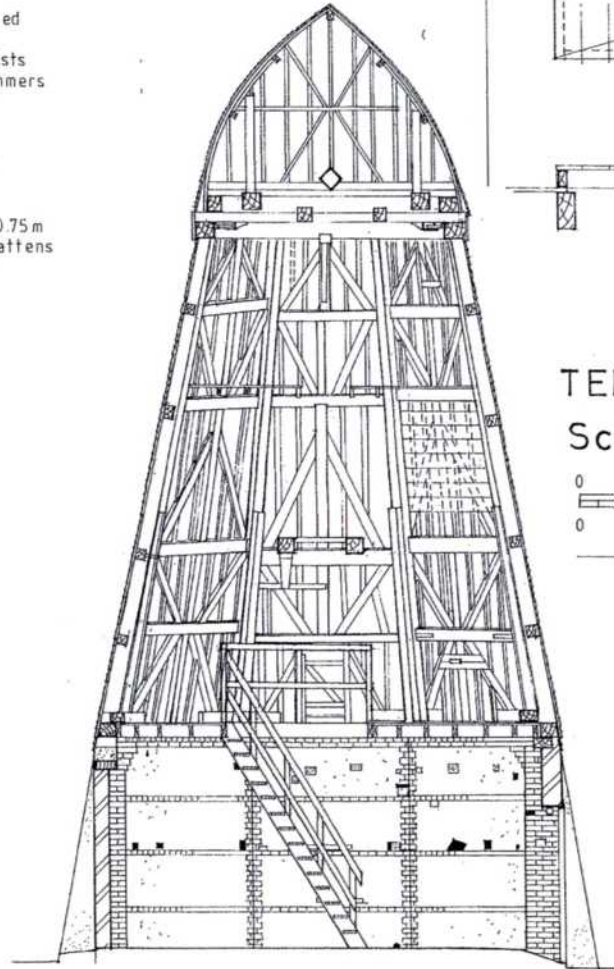

SECTION A-A

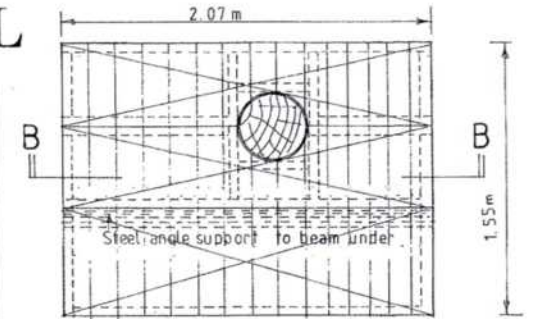

PLAN

25mm SW boarding
50x100mm SW joists

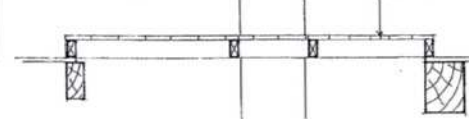

SECTION B-B

TEMPORARY PLATFORM
Scale 1:20



ROTTINGDEAN WINDMILL
NEVILL ROAD,
ROTTINGDEAN

ROTTINGDEAN PRESERVATION
SOCIETY

*NEW INTERNAL STAIRCASE
TO FIRST FLOOR AND
TEMPORARY PLATFORM*

DRAWING No. M/1

SCALES : 1:50 and 1:20 (on A 2 sheet)

DATE : Nov. 2002

DRAWN BY and © R.G.Martin

SCALE

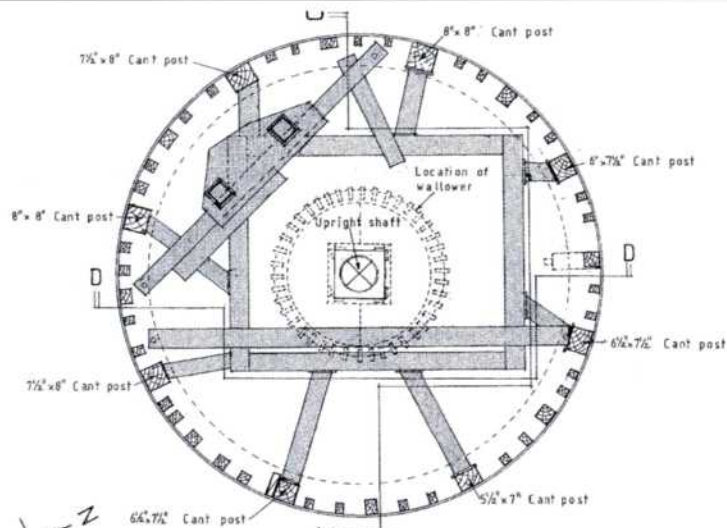

PLAN UNDER CURB

KEY TO MATERIALS	
	Section Elevation
'Original' hardwood	
'Recent' hardwood	
'Original' softwood	
'Recent' softwood	
Brickwork	
Concrete	
Flint rubble	
Structural steelwork	
Voids	
Wooden pegs	
Steel bolts or coach screws	
Embedded timbers cut off flush with wall face	
Extent of floor boarding	

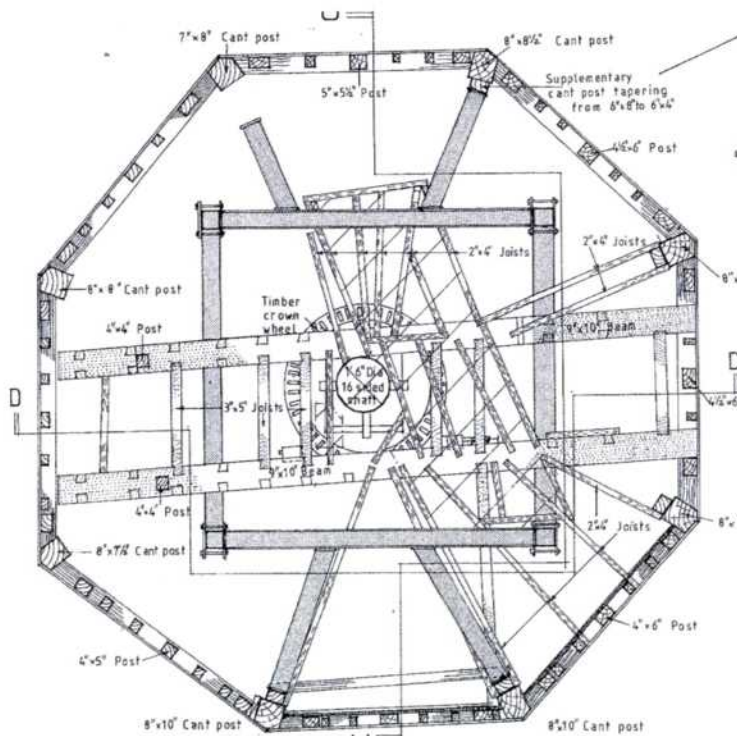

SECOND FLOOR PLAN SHOWING STRUCTURE (BIN FLOOR)

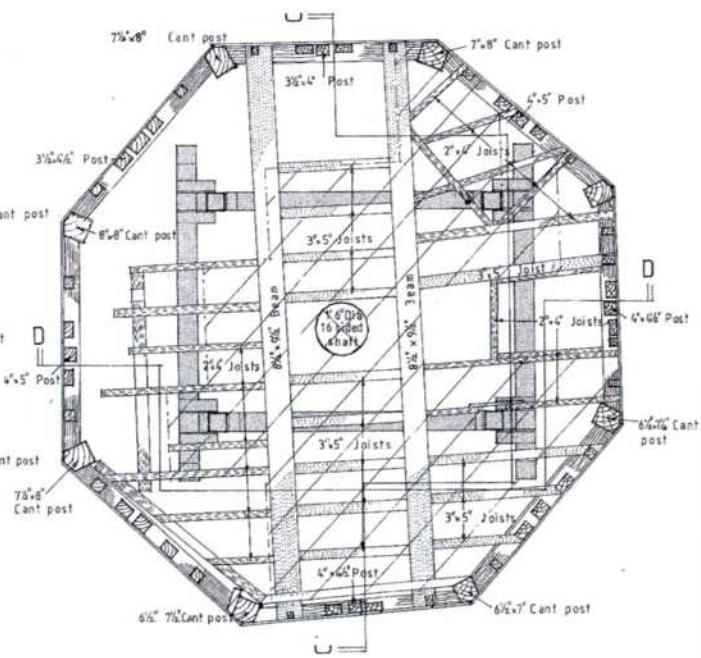

THIRD FLOOR PLAN SHOWING STRUCTURE (DUST FLOOR)

**ROTTINGDEAN WINDMILL
NEVILL ROAD, ROTTINGDEAN
BRIGHTON**

ROTTINGDEAN PRESERVATION SOCIETY

PLANS AT SECOND AND THIRD FLOOR LEVEL
AND UNDER CURB

DRAWING No. M/7

SCALE : 1:20 (on A1 sheet)

DATE : June 2003

Drawn by and © R.G.Martin

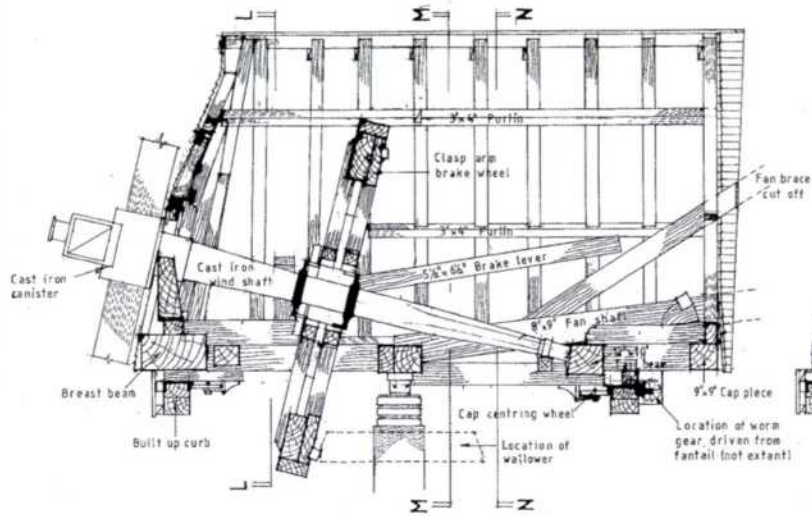

SECTION K-K

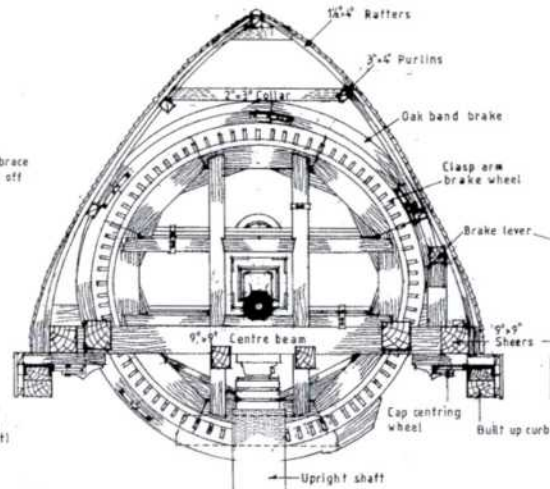

SECTION M-M

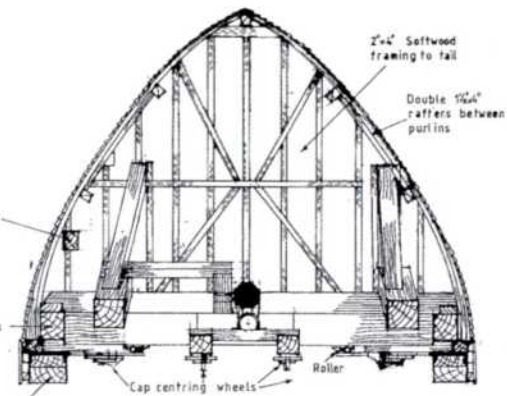

SECTION N-N

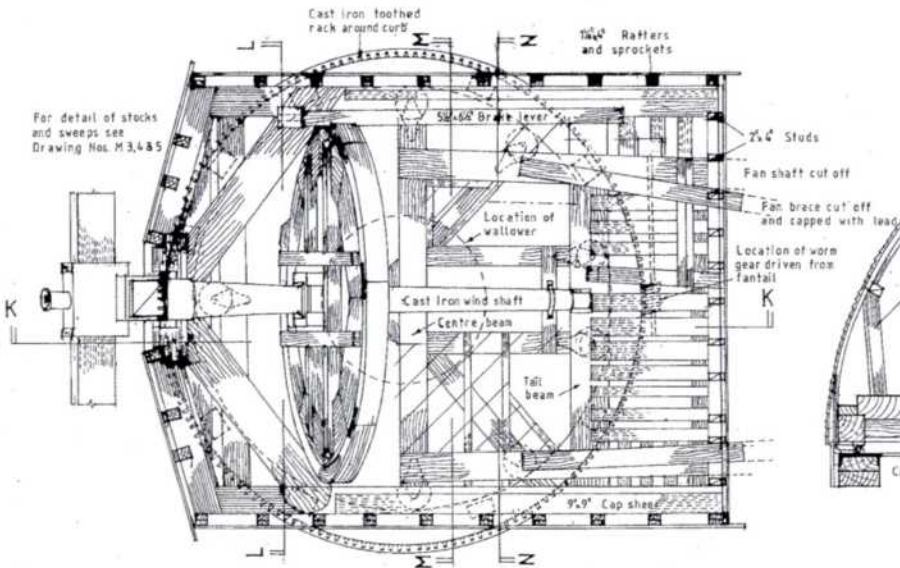

PLAN

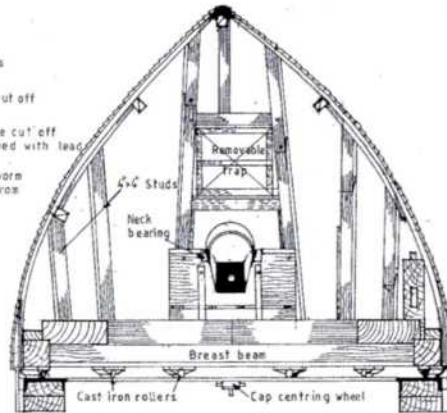

SECTION L-L

KEY TO MATERIALS	
Section Elevation	
"Original" hardwood	
"Recent" hardwood	
"Original" softwood	
"Recent" softwood	
Wooden pegs	• • •
Steel bolts or coach screws	• • •

**ROTTINGDEAN WINDMILL
NEVILL ROAD,
ROTTINGDEAN, BRIGHTON**

ROTTINGDEAN PRESERVATION SOCIETY

CAP, PLANS AND SECTIONS

DRAWING No. M/12

SCALE: 1:20 (on A1 sheet)

DATE: June 2003

Drawn by and © R.G.Martin

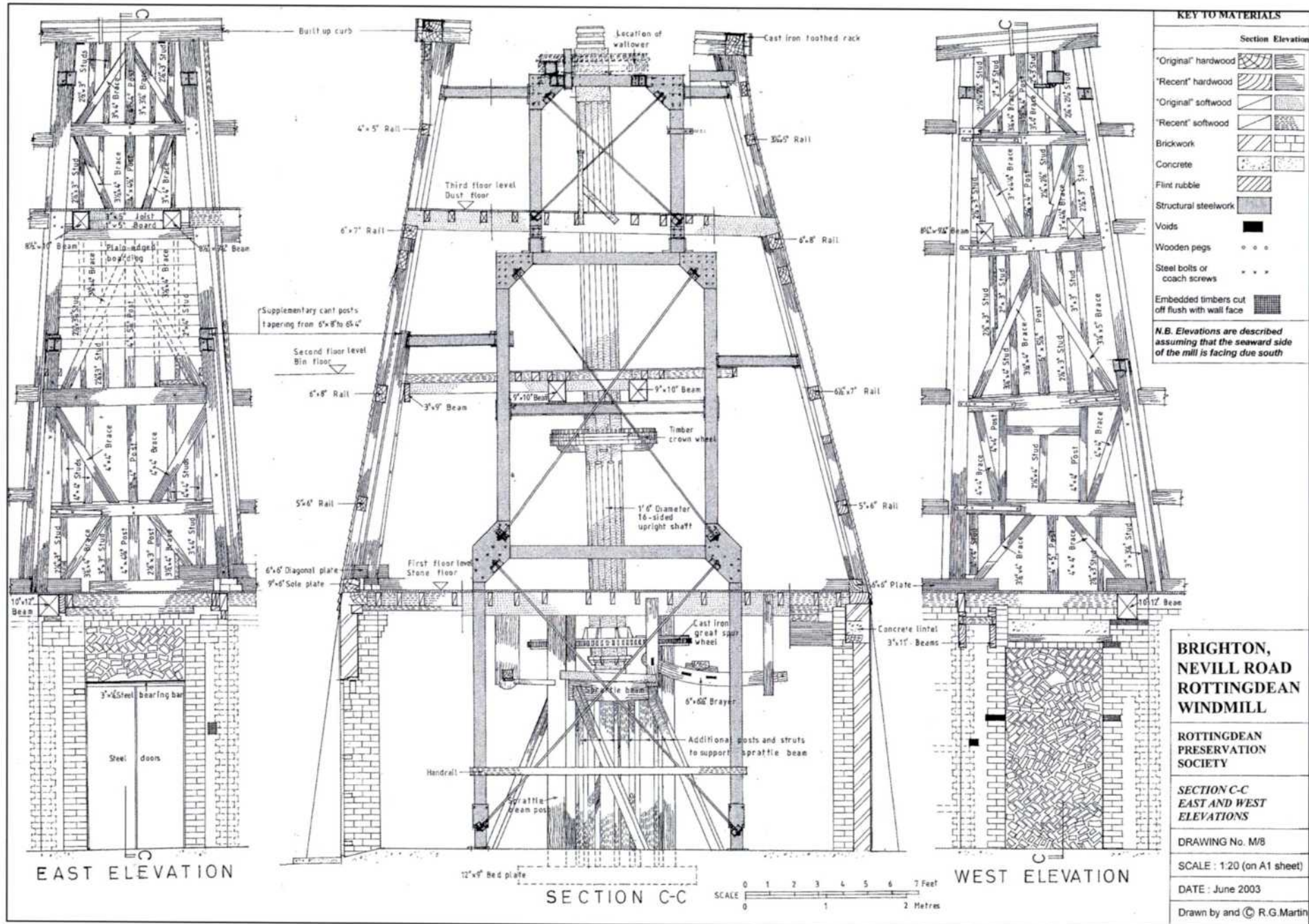

TURNPIKES TO HORSHAM

Brian Austen

Horsham was the largest town in the northern Weald of Sussex with a population of 5,105 at the time of the 1831 census, compared with 3,364 for East Grinstead, its nearest rival. It was growing rapidly in the first three decades of the nineteenth century with a 59.3% increase in population over the period¹. It was the centre of an important agricultural region and in the parish of Horsham alone 57.75% of the land was arable. There was a weekly market for corn, described in the 1839 edition of Pigot as a "large one", and another for poultry aimed at supplying the London market. In addition six fairs were held annually at which cattle, horses and sheep were offered for sale. Although the town did not enjoy the benefits of the seat of a member of the nobility, as Petworth and Midhurst did, it was noted that "many good seats and mansions are in the vicinity". The Assize Court met

in the town in July and in 1806 the Courthouse was enlarged and the town boasted the presence of the County Gaol. It sent two members to Parliament up to the Reform Act of 1832 and thereafter one².

Its prosperity and importance as a supplier of the London market was to make Horsham an important route centre. An Act of 1696 had turnpiked the road from Reigate to Crawley but this was only for pack animals³, and no direct turnpike connection to London by this route was possible until the turnpiking of the Sutton to Reigate road in 1755⁴. Further, the roads of the north Weald had a reputation for being almost impassable in winter and even unsatisfactory in the summer months when the clay dried out⁵. There was a pressing need for a good and direct road connection with London, and the opening of the Horsham and Epsom Trust in 1755 did much to enhance prosperity⁶. Nine years later the Horsham and Steyning Trust was set up, providing a connection between Horsham and the South Downs at Steyning from where the dry back of the chalk could be accessed for east and west

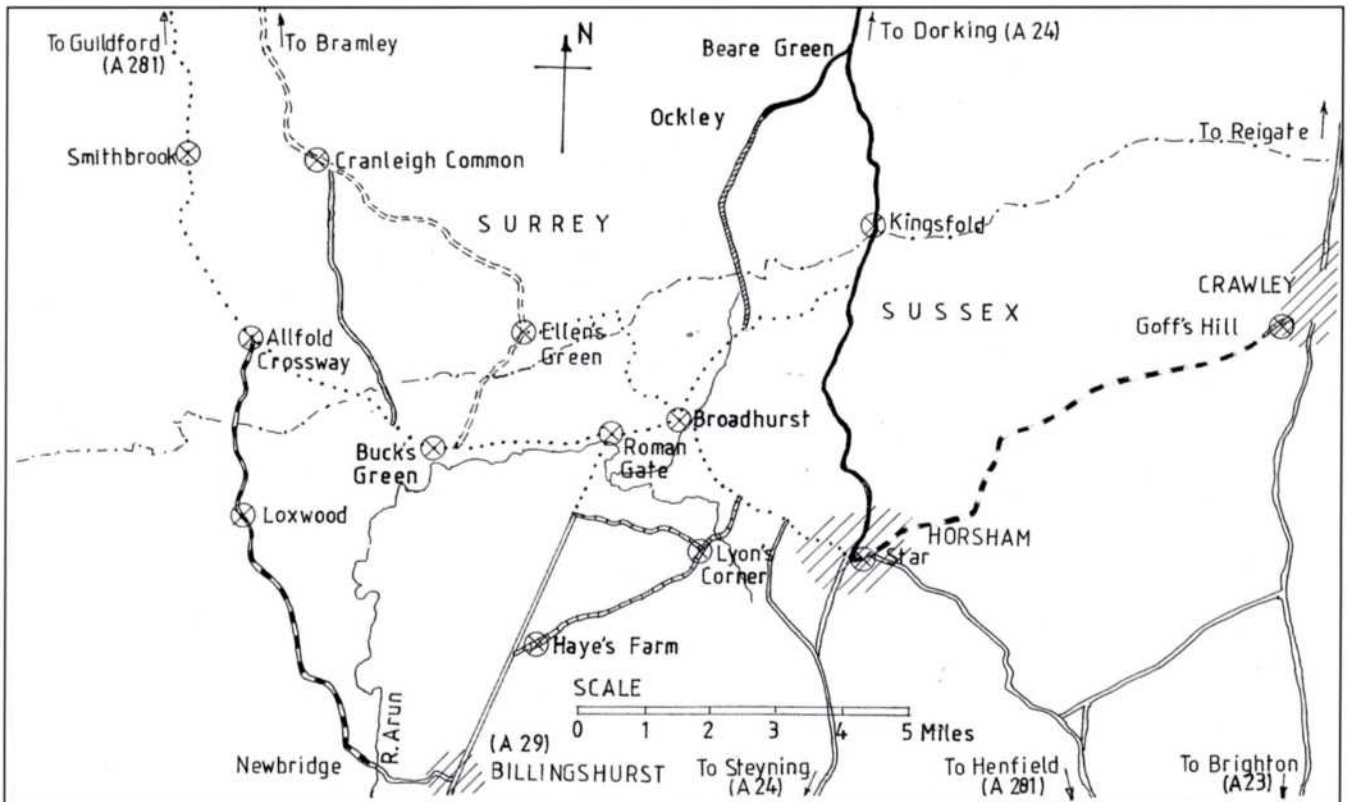

TRUSTS		KEY	
	HORSHAM AND EPSOM		OTHER ROADS AND TRUSTS NOT INCLUDED
	ALFOLD BARS AND NEWBRIDGE		LOCATION OF TOLL HOUSES
	HORSHAM AND GUILDFORD		COUNTY BOUNDARY
	FIVE OAKS		
	HORSHAM AND CRAWLEY		
	BRAMLEY AND RUDGWICK		
	OCKLEY AND WARNHAM		

Fig. 1 Turnpikes of the Horsham area (map by Ron Martin)

communication⁷. A further turnpike route was provided by the extension of the Cowfold and Henfield Trust north to Horsham in 1792⁸.

East to west communication was, as often the case, to wait until the new century when a flurry of activity brought into being to the west towards Guildford:

The Horsham to Guildford Trust (1809)⁹ with its Rowhook Branch (1830)¹⁰

The Five Oaks Trust (1811)¹¹

The Ockley and Warnham Trust (1812)¹²

The Bramley and Rudgwick Trust (1818)¹³

and to the east of Horsham:

The Horsham and Crawley Trust (1823)¹⁴

This transport hub led the compiler of the 1839 edition of *Pigot's Directory* to comment on the "great thoroughfare situation" which ensured the town "business and consequence, and inspired an air of liveliness". It became by the end of the 1830s a significant coaching hub with three routes to London on all days of the week with the exception of Sunday, and further routes to Brighton (twice daily), Worthing (twice daily) and Windsor and Oxford¹⁵.

The Horsham and Epsom Trust (1755)

A petition to Parliament for road improvement was first made in 1750 and four years later a further petition declared the roads to be "so ruinous and bad that in the winter season are almost impassable for any manner of carriages and very dangerous for loaded horses". A bill was presented to the House in the same year by Sir Lionel Pilkington, the M.P. for Horsham¹⁶. The road followed the line of the present A24 to Dorking, if twentieth century bypasses are ignored, through the Mole gap via Mickleham and Leatherhead and then east through Ashstead to just short of Epsom town. It also controlled a branch from Beare Green to Ockley (now part of the present A29). The original powers of the Act of 1755¹⁷ were renewed subsequently in 1776, 1802, 1824, 1858 and 1879. The Trust was finally wound up on 1 November 1880. Traffic increased along the line of the road, which allowed agricultural produce greater access to markets, including London. It was claimed that rents on agricultural land along the route rose from 7s (£0.35) to 11s (£0.55) an acre once the turnpike was open¹⁸. Coaching traffic to London

was to develop and by 1839 there were three daily services on weekdays and one on Sunday via Dorking, and a further service via Kingston. Railway competition came with the opening of Horsham station in 1848 removing much London traffic, and the opening of the Horsham to Dorking line in May 1867 resulted in the loss of local traffic. Advertisements placed in 1820, inviting tenders for the farming of the tolls, list six gates all within Surrey. There is however some evidence to suggest that there was for part of the time a side gate at Warnham. This is mentioned in the accounts of the Treasurer of the Trust, John Evelyn, in 1776, when payment of 10s 6d (£0.53) was made for a special messenger "sent to London to ensure that an advertisement was placed in the *General Evening Post* "touching the erecting of a side gate at Warnham". Such a gate, if established, was probably short-lived, as it is not recorded on subsequent maps, road books, advertisements and documents²⁰.

Tollhouses

The Surrey gates named in July 1820²¹ were at:

Kingsfold - just north of the Sussex border

Holmwood - at Holmwood Corner, near Vigo Farm, South Holmwood and close to Holmwood station.

Harrow - Dorking, Horsham Road at the junction with Hampstead Road. In 1857 the gate was relocated further south just past the Bush Inn.

Leatherhead Gate

Leatherhead Church - probably a side gate²².

A parliamentary return published in 1840 shows the Trust with seven gates and one side bar²³.

Milestones

Although the toll houses on this Trust appear to have been demolished, a number of milestones survive, some of them being on the Sussex section from Horsham to Kingfold. These are of two main types, stones displaying metal plates giving distances to London (Westminster Bridge), and replacement cast iron posts of triangular cross-section from the last years of the nineteenth century.

Horsham Park TQ 172313

A stone block with a semi-circular top, in height 2ft 4in (71cm) from ground level and 1ft 2in (36cm) wide. The side facing the road has a depression into

which a metal plate originally fitted. The 1875 6" O.S. map states that this originally displayed the distance to London as 36 miles. Both the 1896 and 1932 25" O.S. maps show the milestone as 'defaced' and this must mean that the plate was missing. Recently a replacement plate was fitted based on the Capel milestone recorded below. The stone stands on the east side of the road beside Horsham Park and faces Rushmans Road.



Fig. 2 Mile post cast by Steele & Dodson c1890 at TQ 163338 Warnham

Warnham TQ163338 (fig. 2)

A cast iron post of triangular cross-section bearing on the sloping top the word 'WARNHAM'. It is on the east side of the road just to the north of Station Road. The south face reads '34 MILES/TO/LONDON/11 MILES/TO/DORKING' and the north face '24 MILES/TO/BRIGHTON/2 1/2 MILES/TO/HORSHAM'. The post is painted white with the lettering in black and it stands 2ft (61cm) from the ground and is 1ft 6in (46cm) wide.

Warnham TQ167352

A further cast iron post, 200 yards south of the *Dog and Duck* public house. The sloping top face reads 'WARNHAM', the south face '33 MILES/TO/LONDON/10 MILES/TO/DORKING' and the north '25 MILES/TO/BRIGHTON/3 1/2 MILES/TO/HORSHAM'.

Warnham TQ169367

Originally stood outside Milestone Cottage but when seen was on private property awaiting restoration and returning to its original position

beside the road. The post and type of inscription is identical to the other Warnham posts, showing the distance to London as 32 miles, that to Dorking 9 miles, to Brighton 26 miles and to Horsham 4 1/2 miles. As the post was not in situ it was possible to ascertain its full height as 3ft 6 1/2in (108cm) and to note the name of the firm responsible for their casting 'STEELE & DODSON/ HORSHAM'. This manufacturer was active 1886-97 and their works was near Horsham station. In 1897 H. & E. Lintott took over the business²⁴. This supports the assertion that these were replacement posts manufactured immediately following the taking over of the main roads by the newly established West Sussex County Council in 1889. This type of post also appears on the Sussex section of the Horsham and Guildford Trust.

These are the only distance markers found to the south of the Surrey border, but north of it at Capel (TQ 177412) is a milestone outside 17, High Street on the east side of the road (fig. 3). This is the same type as that at Horsham Park but with the original cast iron plate reading '29/FROM/WEST^R/BRIDGE'. The plate is 9in (23cm) square and the height of the stone above ground level is 2ft 5in (74cm).



Fig. 3 Milestone with cast-iron plate at Capel, Surrey

The Alfold Bars and Newbridge Trust (1757)

This Trust had its origins in an Act of 1757²⁵ for a turnpike from 'Stoke-next-Guildford (Dapon Wharf)' through Shalford, Bramley, Alfold, Loxwood, Pulborough, Hardham, Coldwaltham and Bury to

Arundel. The scheme was ambitious but the resources and the traffic insufficient to maintain it. In 1799 the section south of Newbridge was abandoned²⁶ and ten years later the section north of Alfold became part of a new turnpike connecting Guildford to Horsham²⁷. This left a mere 5 miles and 5 furlongs of road for the Trust to maintain with only one tollgate at Loxwood. Traffic was sparse, income low, and the Trust had the distinction of never being able to redeem or even pay interest on the funds raised in 1757 for the improvement of the road. Its powers expired on 1 November 1876²⁹. The line of this Trust is the B2133 from Alfold Crossway on the A281 to the A272 at Newbridge where it connected with the Wey and Arun Junction Canal. A further connection was made with this canal at Loxwood, and after 6 April 1843 no toll was taken on any horse going or returning from Loxwood Wharf laden with chalk or lime. It was by way of the wharves at Newbridge and Loxwood that the Trust received gravel and flints brought by canal for road maintenance. Some of the gravel was conveyed by barge from Littlehampton³⁰.



Fig. 4 Loxwood tollhouse March 1938

Tollhouses

Only one tollhouse existed on this Trust and this was at:

Loxwood TQ 042311 (fig. 4)

The tollhouse was on the east side of the road immediately to the north of the bridge over the River Chid or Lox, and to the south of the *Onslow Arms* public house. A plot of land extending north from the bridge was owned by the trustees and was

probably used as a garden for the tollhouse keeper³¹. The tollhouse was of three bays and two storeys, at the edge of the road, with small side windows from which the traffic could be observed. It was of brick construction with a hipped, tiled roof and two prominent chimney stacks and thus a more substantial building than those usually built by turnpike trusts. It may possibly have been an existing house bought by the trustees because of its convenient position. It was demolished in 1962 when the bridge and its approaches were widened³².

During the nineteenth century the trustees alternated between directly employing a tollhouse keeper and the more usual practice at that time of farming the tolls. The latter course of action was encouraged by the unreliability of the keepers appointed directly by the Trust, which only paid a sparse 4s (£0.20) a week for their services. In July 1821 James Puttock was removed "for fraud and neglect of office" and spent a short while in the Petworth House of Correction. Wages were raised to 5s (£0.25) in 1826 but the keeper appointed, Henry Reeves, was also removed "for fraud and neglect of his office" three years later. The tolls were farmed in 1808 to Henry Cuddington of Shoreham for £121 but his tenure lasted but briefly, being forfeited in April 1809 because of his failure to comply with the payment provisions. Farming was regularly used from April 1838 with the gate being leased for as much as £120 10s (£120.50), but as little as £83 5s (£83.25) in 1838, and £85 in both 1850 and 1853. The 21 year average at this time was £99 15s 6d (£99.78). At these levels the income was barely sufficient to maintain the road³³. In 1876 the tollhouse was sold for £84 to James Overington of Loxwood, described as a labourer³⁴.

Milestones

Alfold TQ 038339

The stone is on the east side of the road outside a house called 'Hillside' and facing the Green and Church. The stone is of triangular cross-section, the north face reading 'GUILDFORD/(10)/MILES' and to the south 'HORSHAM/10/MILES'. The sloping face at the top of the stone reads 'ALFOLD' and 'BRIGHTON/32'.

Milestone Cottage TQ 062268

On the east side of the road, a stone block of the same triangular pattern, but with the inscriptions illegible.

The milestones on this Trust are of the same pattern as those along the Guildford to Horsham Trust of 1809 and this might suggest that these date from a period prior to this date when the road was part of the Guildford to Newbridge (or Arundel) Trust³⁵. Supporting this theory is the fact that no stones of this pattern exist on the post-1809 Alfold to Horsham line of road only created as a turnpike in that year. Countering this early date for these stones is the information contained in the Alfold and Newbridge Trust minute books. In February 1827 it was ordered that milestones be erected to indicate the distance from Guildford to Worthing. It is possible that the two Trusts cooperated at this date to provide a standard pattern of milestone, though if this was the case, why does the existing stone, whose inscription can be read, record distances to Brighton rather than Worthing?³⁶

Horsham and Guildford Trust 1809

A meeting to obtain a parliamentary Act to improve road communication between Guildford and Horsham was held in Guildford on 25 October 1806, but it was not until 1809 that an Act was passed into law³⁷. The Turnpike, described in parliamentary returns as 25 miles and 3 furlongs in extent was formed in part from the existing Guildford to Newbridge Trust, as far as Alfold Crossways, and in part a substantially new line of road from this point to Broadbridge Heath, with an improvement to the existing line of parish road from this point into Horsham. The old route by way of parish roads passed through Slinfold to Broadbridge Heath and was both narrow and circuitous. In essence the 1809 Turnpike is the line of the present A281 road with the exception of the section from Alfold Crossways to the junction with the B2130 to Goldalming. During World War II the line of the original road was diverted to the east to allow the construction of Dunsfold Airfield, leaving only short stubs of the original public road at the southern and northern ends. The 1809 scheme also turnpiked two branch roads:

A south-westerly extension of just under two miles from the main road to Park Street to service the village of Slinfold which the Turnpike had by-passed. This is now part of the A29.

A north-easterly extension of about five miles from near Broadhurst to meet the Horsham to Epsom Trust at Kingsfold which is now part of the A29.

All the gates were on the main line of the Turnpike.

Once established, the only addition to the Turnpike was in 1830³⁸, when a new branch was built from near Broadhurst by way of Rowhook to meet the Rudgwick to Bramley Trust (B2129) at Ellen's Green, just north of Rudgwick. The distance of the Rowhook Branch was 3 miles and 2 furlongs and the road is today unclassified. The Horsham and Guildford Trust had its powers renewed several times before its final winding up on 1 November 1878³⁹. The Trust does not appear to have been a financial success. Some stage coaches used the route, the 'Hero' from Brighton to Oxford three times a week and the 'Royal Sovereign' from Brighton to Windsor with the same frequency⁴⁰, but most of the traffic must have been local conveyance with no regular carrier services being advertised. The financial returns for 1829 show an income of £526 but expenditure of £1,329 13s 9d (£1,329.69) and accumulated debts of £25,902 17s 4d (£25,902.87) of which £14,662 3s (£14,662.15) arose from sums originally raised for construction and improvement⁴¹. Despite this, the road was being maintained and in 1840 it was reported that "the condition is good for the season of the year, and no part is under indictment"⁴². By January 1851 the Trust was admitting that it had paid no interest on its debt for more than 35 years⁴³. The opening of the Horsham to Guildford railway line in October 1865 would have been detrimental to the Trust's income.

Tollhouses

Three of the toll gates were in Sussex and these were located at:

Broadhurst TQ 135331

This gate was situated between Strood Green and the present A29 and A281 junction at a point where a minor road, extending west from Warnham connected with the A281. The tollhouse was on the south side of the minor road facing the turnpike on a plot extending to 11 perches and was in the parish of Slinfold. In 1843 the gate keeper was named as Nathaniel Cook⁴⁴. No illustration of this tollhouse has been located, nor is it known when it was demolished, but it may have been at the time of the winding up of the Trust, or soon thereafter.

Roman Gate TQ 119333 (fig. 5)

Situated at the intersection of the present A29 and A281 at the point that the A29 towards London ceases to follow the line of the Roman Stane Street



Fig. 5 Roman Gate tollhouse, Slinfold, c1930 (*West Sussex Gazette*)

and deviates to the east. The name of the gate would appear to be taken from its location on Stane Street. The house was situated on the south side of the A281 with one side facing the A29 with a gate across the Horsham and Guildford turnpike. The house plot and garden extended to 11 perches and were in the parish of Slinfold. In 1843 the gate keeper was James Grinstead⁴⁵. The house was demolished in the 1930s in connection with road widening but lasted long enough to be photographed. It was a single-storey brick structure and the face to the A281 displayed a central doorway with two flanking windows. Additions were subsequently made to the west and south of the original building⁴⁶.

Bucks Green TQ 082329

Situated at the intersection of the A281 and a minor road leading south to the A29 at Buckman Corner. On the title award map the tollhouse is shown as a narrow building with only one bay facing the turnpike, and the longer face is to the minor road. Together with its garden, the plot extended to 7 perches and in 1840 the house was occupied by James Grinstead, probably the keeper of the Roman Gate in 1843. A modern two-storey house is on the plot today⁴⁷.

North of the county border in Surrey the sites of three tollhouses have been located:

Alfold Crossway TQ 039353

A dwelling of two storeys with tile-hung walls called 'Tollgate' exists on the south side of the road where the new line deviates from the former route, now blocked by Dunsfold Airfield. It has a single-storey extension to the west in stretcher bond. The dwelling may incorporate parts of the original tollhouse. There is evidence of considerable

alteration to the road junction at Alfold Crossways in the period following the changes of 1809 which established the new Trust⁴⁸. In August 1820 the farm of the tolls at a Wildwood Gate was advertised, and this may be another name for Alfold Crossways⁴⁹.

Smithbrook TQ 026396

Also known as the Leathern Bottle after an inn immediately north and on the same side of the road. In 1877 the tollhouse was sold to Henry Townsend for £57 10s (£57.50). It no longer survives and the inn is now a private house called 'Smithbrook Gate'⁵⁰.

Shalford SU 999483

Was opposite Shalford Park on the corner of Pilgrims Way and was demolished in the 1930s for road widening. A photograph shows a two-storey house of three bays with a hipped roof, with a lean-to extension at one end possibly later in date⁵¹. A large three-bay house on the corner of Pilgrims Way, but facing the main road, has a plate on the front '2/TOLLGATE/HOUSE'.

A Farzon Gate was mentioned in connection with the Rowhook branch but its location is not known.

Milestones

On the Sussex section of the Trust none now survive in situ. One has however survived and is on display at the Amberley Working Museum on permanent loan from the SIAS (fig. 6). This is a cast iron post of triangular cross-section identical to those on the Horsham to Epsom Trust road within Sussex. It was originally situated at TQ 064341 close to the Sussex

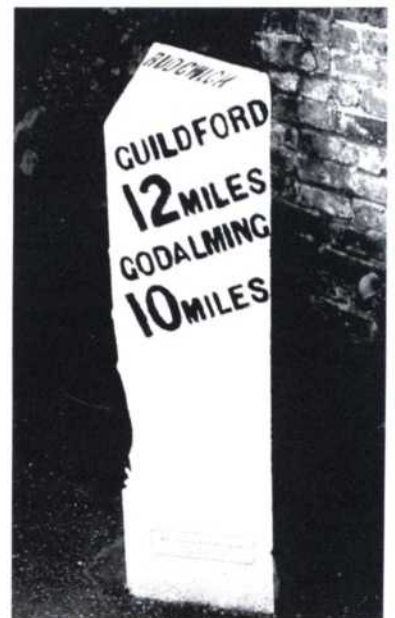

Fig. 6
Milepost by
Steele &
Dodson,
originally near
Rudgwick

border and bears the name 'RUDGWICK' on the sloping top face. The damaged northern face bears the inscription 'HORSHAM/8 MILES/BRIGHTON 2-/RUDGWICK/-' and the southern side 'GUILDFORD/12 MILES/GODALMING/10 MILES'. The post was found uprooted and damaged in April 1970 and was taken to the Divisional Superintendent's yard at Horsham from whence it was taken into the care of the Society. It bears the founder's mark of STEELE & DODSON/HORSHAM'. Like those on the Horsham to Epsom road it is a late nineteenth century replacement.

In April 1970 a milestone was recorded at Broadbridge Heath at TQ 146317 (fig. 7), but was no longer there in 2006⁵². The milestone had a semi-circular top and was inscribed 'HORSHAM/ 2 MILES/ BRIGHTON/ 24 MILES'.



Fig. 7
Milestone at
Broadbridge
Heath
April 1970

North of the Sussex border three stones of triangular cross-section are to be found at:

Shalford TQ 000464 'GUILDFORD /2/ MILES/
HORSHAM/18/MILES/ BRIGHTON/40/MILES'

Bramley TQ 015439 'GUILDFORD/4/MILES/
HORSHAM/16/MILES/ BRIGHTON/38/MILES'

Palmers Cross TQ 026411
'HORSHAM/14/MILES/BRIGHTON/36/MILES'
(fig. 8)

These are uniform with the surviving stones on the Alfold and Newbridge Trust.

In 1988 another stone of this pattern, reading 41 miles to Brighton, was recorded at TQ 999480 on the

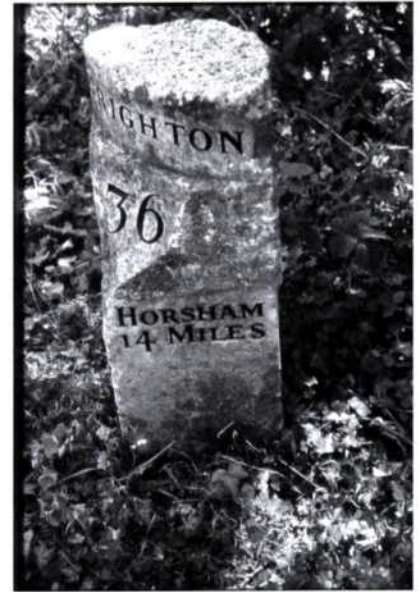

Fig. 8
Milestone at
Palmers Cross,
Surrey, of a
type used on
both the
Horsham and
Guildford and
the Alfold Bars
to Newbridge
Trusts

east side of Shalford Road, Guildford. The Bramley stone was repaired by the Surrey County Council after being broken by a vehicle c1988 while that at Palmers Cross has had its inscription renewed since this time. It is on the west side of the road but was originally on the east side near 'Milestone Cottage'⁵³.

The Five Oaks Trust 1811

The Act passed in 1811⁵⁴ gave the trustees powers to take over the existing parish road from the newly formed Horsham and Guildford Trust at Broadbridge Heath to Slinfold village and also permitted the building of an entirely new road, from the point where the parish road turned west to serve the village, as far south as the line of Stane Street. This main line of road from Broadbridge Heath to Five Oaks is now the A264. It shortened the distance between Horsham and Billingshurst, Pulborough and Arundel, but otherwise appears to have had little significance. The Trust was 4 miles and 5 furlongs in length and had two toll bars. Two years earlier a more ambitious scheme had been to turnpike in addition the road south along the A29 to make a junction with the Bury Trust road about two miles north of Bury village⁵⁵. The survey was made by John Heath, the road being 15 miles and 6 rods from its start at Broadbridge Heath and the cost was estimated to be £6,071 14s 9d (£6,071.74)⁵⁶.

It was probably the lack of funding which caused the scheme to be cut back to Five Oaks. Work was carried out under the direction of John Heath but was not complete until June 1813. Construction was only completed then because the Duke of Norfolk agreed to provide additional funds of £395, and the

Earl of Egremont a similar sum, to cover the deficiency. Tolls collected at the Lyons Corner and Hayes Farm tollgates were to be transferred to Charles Grinstead of Horsham who acted as Treasurer until October 1816 when he was declared insolvent. Traffic was never sufficient to provide full interest payments to those who had provided the funds for the scheme and by April 1823 these were already £2,400 in arrears. Income was reduced by a clause in the original Act which specified that only a third of the authorised toll could be collected from residents and non-resident owners of land and property in Slinfold who were travelling to Horsham, and the erection of a tollhouse on the road through the village from Lyons Corner to Newbridge was also excluded⁵⁷. Railway competition must have worsened matters. The line from Horsham to Pulborough was opened in October 1859 and four years later extended through Arundel to the Brighton and Portsmouth line. In October 1865 Slinfold was provided with a station on the Horsham to Guildford line. Despite this the Trust struggled on until its powers finally expired on 1 November 1876⁵⁸.



Fig. 9 Lyons Corner tollhouse, Slinfold, awaiting demolition April 1970

Tollhouses

Lyons Corner Gate, Slinfold TQ 138308 (fig. 9)

Located at the corner where the road to Slinfold turns west off the A264. It was on the west side of the road with gates across both roads. The house was probably complete by July 1813 when Cornelius Voice was appointed collector at 6s (£0.30) a week. Charles Child was paid £112 14s 10d (£112.74) for carpenter's work in connection with the tollhouse and gates and John Greenfield £82 0s 9d (£82.04) for brick-layer's work in November of the same year⁵⁹. A substantial plot of land extending to 25 perches was employed for the house and garden⁶⁰. In April 1970 the house was hit and severely damaged by a lorry and demolished a few months later. In its final phase it was a two-storey brick cottage with a 13ft 8in (4.17m) frontage to the Horsham road, and extending back along the Slinfold village road for 21ft 6in (6.56m) in its original form⁶¹, although two further lean-to extensions were later added. It may however have been a single-storey structure when first built.

Hayes Farm Gate TQ 105288

On the west side of the road 36 chains (723m) from the junction with the A29 at Five Oaks opposite the Brick-kiln Field and within the boundary of the highway and without any garden. It was not constructed until 1828, 19 years after the opening of the Trust. A contemporary plan shows a two room bungalow with a central door (fig. 10). The rooms, named as a bedroom and a kitchen were each 10ft (3.05m) by 8ft (2.88m). At the east end was a small privy, accessible from the outside⁶². A Horsham stone floor was specified for the kitchen, oak door and window frames, the windows glazed with diamond panes, lath and plaster ceilings and a tiled roof. Six tenders were received to construct the house ranging from £61 to £80 and the lowest was accepted. The gate keeper was paid 4s (£0.20) a week, and takings in July 1832 were between £2 and £3 weekly, compared with £3 to £4 at the Lyons Corner Gate. The reason for the establishment of this second toll gate is unclear. The date of its demolition is unknown, but its position within the boundaries of the road would suggest an early demise, possibly when the Trust was wound up in 1876⁶³.

Milestones

None were located and none were recorded on the 1914 1" O.S. map.

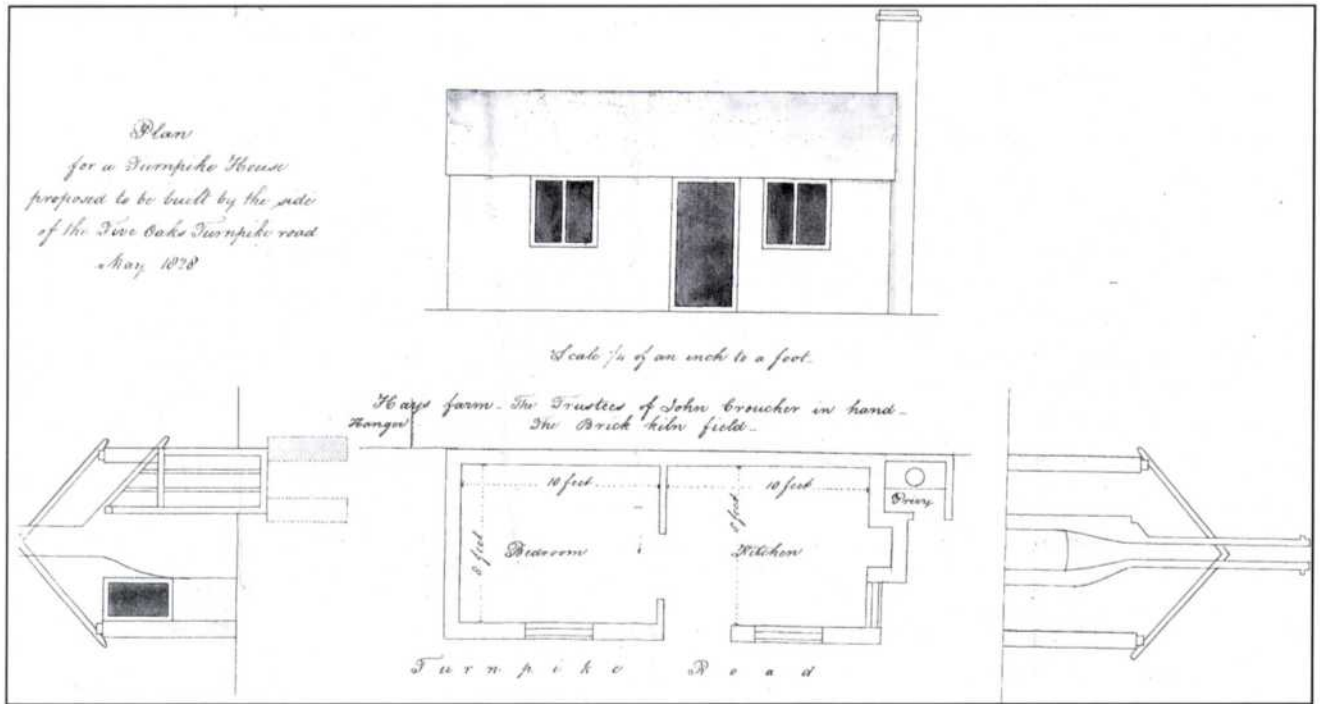

Fig. 10 Plan for Hayes Farm tollhouse 1828 (WSRO)

The Ockley and Warnham Trust 1812

The 1755 Act for the Horsham and Epsom Trust had included a branch road from Beare Green, north of Capel to the village of Ockley. The 1812 Ockley and Warnham Trust⁶⁴ continued this branch south to make a junction with the Horsham and Guildford Trust branch to Kingsfold. It was three miles and three furlongs in length and had two gates. It is currently part of the A29. Most of the length of the Trust is in Surrey with about a mile of the southern end in Sussex. The gates were north of the Surrey border and no tollhouses have survived.

In 1840 the condition of the road was reported to be good and interest was being paid on the £3,600 of debt⁶⁵. The Trust would subsequently have been affected by railway competition losing its through traffic to the coast from London and it was wound up in 1866⁶⁶.

Milestones

Ockley TQ 145398

The milestone at this location has a semi-circular top standing 3ft 6in (102cm) from the ground, 1ft 8in (51cm) wide and 4½in deep, bearing an inscription 'LONDON/31/PULBOROUGH/15/ARUNDEL/24/BOGNOR/31'. It does not look to be of 1812 and may be a later replacement. Bognor in 1812 was hardly significant enough to be likely to be mentioned on such a direction stone.

Denne Bridge TQ 144365

Just to the south of the Sussex border, and erected by the trustees as part of their road improvements, was a new bridge which bore the inscription 'DENNE BRIDGE/ from/ LONDON 33 miles 1 furlong/ 1812'. Subsequently an Ordnance Survey arrow was superimposed on the inscription. The bridge was rebuilt in 1955 and the stone passed to the care of the Sussex Archaeological Society and was stored at Anne of Cleves House, Lewes⁶⁷.

Bramley and Rudgwick Trust 1818

This Trust controlled the present B2128 road, forming a junction with the Horsham and Guildford Turnpike (A281) at the southern end and proceeding through Rudgwick, Cranleigh and Womersley to join the A281 again at Bramley. It was set up in 1818 and declared in parliamentary returns to be 6 miles and 1 furlong in length and had three gates. With the exception of just over a mile at the southern end it was entirely in Surrey⁶⁸. In fact the distance from Bramley to the southern end is nine miles and it would appear that the northern section to the gate at Gaston was never completed. The reason for this appears to be connected with the way the Trust was administered. Despite its short length it was controlled by two boards of trustees, one for the southern and one for the northern district. The northern (known as the first) division trustees

appear to have been unable or unwilling to build the Gaston to Bramley section. Difficulties were experienced from the start with a reluctance by subscribers to pay over the money pledged to the trustees. Only £3,500 was raised compared with an estimated need for £4,830. The lack of locally sourced road building materials in this area of deep Wealden clays made the cost of repair well in excess of revenue. The building of the parallel Horsham to Guildford railway line which opened in October 1865 made any future pretence to viability impossible. Nevertheless the Trust continued to operate into the 1870s.

Tollhouses

All three toll houses were in Surrey.

Ellen's Green TQ 099355

Built at the point where the Rowhook Branch of the Horsham and Guildford Trust of 1830 made a junction with the Bramley and Rudgwick Trust,⁶⁸ about a mile north of Rudgwick. It was also referred to as the Cox Green Gate⁶⁹. The toll house no longer survives.

Cranleigh Common TQ 050394

Located at the north end of Cranleigh Common where a connecting road from the Horsham and Guildford Trust made a junction. The toll house no longer survives.



Fig. 11 Gaston Gate tollhouse, Surrey c1870

Gaston Gate TQ 042417 (fig. 11)

The tollhouse survives opposite Gaston Gate Garage. It was a simple single-storey dwelling facing the turnpike and the front elevation appears to be original. It is constructed of brick with a tiled hipped roof. It is easily missed as the road alignment has

been altered and it now has a tall hedge hiding it. It is currently named 'Tollgate Cottage'. A photograph of it c1880, in its original form, exists⁷⁰.

Milestones

Only one milestone survives along the line of this Trust and this is the well-known Cranleigh obelisk (TQ 061390) (fig. 12). It is unlikely that this would have been provided by a cash-strapped Trust. Attempts have been made to connect this with John Ellery, one of the subscribers to the Trust whose house was close to it. This is unlikely as Ellery was a reluctant subscriber who as late as 1820 needed to be written to by the Trust's clerk to pay the sums due. The earliest mention of the obelisk is in 1831 when it was described as "a white square column surmounted by a pineapple". The present structure is somewhat less elegant. The square section base is of local paludina limestone (winkle stone), surmounted by a shaft of sandstone blocks, the tapering obelisk above being of brick with a surface render. The total height is 26ft 4in (8m). The cast iron plates are attached to the sandstone section on three sides only and show distances to 'RUDGWICK 5/HORSHAM 10/BRIGHTON 31' on one face, 'EWHURST 2/OCKLEY 6/DORKING 12' on another, and 'WONERSH 5/GUILDFORD 8/WINDSOR 31' on the other. The Ewhurst road was never turnpiked. The plates show the name of the iron founder as 'J. CHAMPION'. The inclusion of 'WINDSOR' as one of the destinations has suggested to some writers that the obelisk was placed here as the Prince Regent (later George IV) used this route on his way to Brighton from Windsor⁷¹. This route may also have been used by the Brighton to Windsor



Fig. 12
Obelisk,
Cranleigh,
Surrey
c1830

stage coach, the 'Royal Sovereign', which was operating in 1839⁷².

The Horsham and Crawley Trust 1823

Although a turnpike Act had been passed as early as 1696/7 connecting Reigate to Crawley⁷³, it was not until much later in the eighteenth century that this road was suited to wheeled traffic. Crawley was a village of little significance at this period and by the time of the first census in 1801 only 210 inhabitants were recorded in the parish. Its significant increase coincides with the growth of Brighton and with attempts to improve access to that town avoiding circuitous routes by way of Horsham or East Grinstead. The last part of what is now the A23 was turnpiked in 1808 in the form of the Pyecombe and Hickstead Trust which utilised the level ground of the Dale Gap to pass through the line of the South Downs, rather than the steep ascents at Clayton, Ditchling and Poyning. As a stopping point on the direct route Crawley flourished. The population had risen to 394 by 1831 and the *George and Rising Sun* were benefiting from the coaching trade. The compiler of *Pigot's Directory* could in 1839 claim that "coaches to and from London were almost hourly during the day". Other than road traffic there was however little prosperity and the village supported only a "very small" weekly market, and fairs for cattle twice annually⁷⁴. The connecting parish road to Horsham was not well regarded and in 1777 the Crawley to Ifield section was described as "a horse road almost impassable for a carriage"⁷⁵. There was, however, sufficient enthusiasm by the early 1820s for a short turnpike of 7 miles and 3 furlongs to connect Horsham to Crawley. Thomas Broadwood of Holmbush House appears to have been the main promoter and subscriber, seeking the personal advice of John Loudon McAdam on the scheme and adopting his views⁷⁶. The Act of 1823⁷⁷ envisaged the improvement of existing parish roads but the influence of Thomas Broadwood is seen in the re-routing of the central section where a new line of road was constructed from Faygate, north of Holmbush House to Bewbush. Formerly the parish road had passed south of the house and close to the parkland.

As with many of the west to east routes in Sussex, it failed to produce the income expected. The agriculture of the Forests and High Weald was marginal and produced little local traffic, the road passed through no intermediate villages of

consequence, and failed to shorten the distance to London from Horsham. Coaches from that town continued to operate exclusively on their existing route through Dorking and the Mole Gap. The mortgage debt of £5,250 was not being serviced and in 1829 it was reported that there was "£500 of interest arrears besides a floating debt nearly £1,000"⁷⁸. The opening of the branch railway line from Three Bridges through Crawley to Horsham in 1848 provided direct competition. In 1851 the Trust was included in a list of ten Sussex Trusts with more than 20 years arrears of interest⁷⁹. The Trust continued for a further 22 years, finally expiring on 1 November 1873⁸⁰.

Tollhouses

There were two toll gates on this Trust, one immediately to the east of Horsham and the other immediately to the west of Crawley. Neither now exist.

The Star TQ 192318 (fig. 13)

This tollhouse, hexagonal in ground plan⁸¹, was on a plot of land 6 perches in extent. It was on the north side of the road to the east of the public house at Roffey from which it derived its name. It was demolished in 1946. It was of brick construction, single storied and with a central chimney stack. When strong winds and snow coming from the east hit Horsham it used to be remarked by the inhabitants that someone had left the Star Gate open⁸².

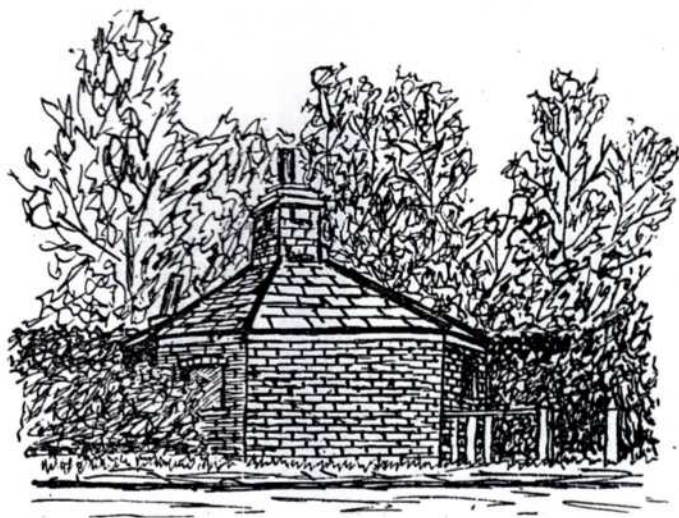

Fig. 13 Star tollhouse, Horsham. Drawing by William Albery

Goffs Hill, Ifield TQ 261361

The gate was also known as Crawley West Gate. It is shown on the Ifield tithe map on the west side of the road just to the south of Goffs Hill Farm on a plot of 15 perches. It has been described as "a round house" but on the tithe map it is a rectangular building. At the time of the 1851 census the house was occupied by James Charman and his wife and he appears to have continued as the gate keeper until the demise of the Trust⁸³.

Milestones

These were of a common pattern, being about 1ft 3¹/₂in (39cm) wide, 5¹/₂in (14cm) deep and 4ft 7in (140cm) above ground level. The corners and the top were chamfered. Mileages were shown to London and Worthing. No fewer than four survive but only one is in situ. This is at the Crawley end 100 yards west of Hillside Close on the north side of the road (TQ 258360). It displays 'TO LONDON/30 MILES' and currently buried, 'TO WORTHING/20 MILES'. The other three are in the garden behind Horsham Museum where they are currently mounted on brick piers and are being used as seats. These give distances of 32, 35 and 36 miles to London and 25, 22 and 21 miles to Worthing. One of these, 32 miles to London, was photographed beside the road, uprooted, on 27 May 1973 (fig. 14). Subsequently these milestones were probably taken to the West Sussex Highways Depot at Horsham and then passed to the Museum. It is likely that their removal is associated with the extensive changes made to the A264 road, converting much of it to a dual carriageway.



Fig. 14
Milestone at
Faygate,
uprooted
May 1973,
now in
Horsham
Museum

The survey of the Horsham and Steyning and the Cowfold and Henfield Trust will be dealt with in a subsequent article covering the Henfield, Steyning and Shoreham areas. A detailed history of the Cowfold and Henfield Trust by John Townsend will be found in *Sussex Industrial History* 37 (2007) and *Sussex Industrial History* 38 (2008) (this issue).

I would like to acknowledge the assistance of John Blackwell and Peter Holtham both in connection with the fieldwork and the research and in commenting on the text. It is very much a team effort. I would also like to thank Ron Martin for drafting the map that illustrates this article.

References

1. Pigot (1839) p239; William Cartwright, *The Parochial Topography of the Rape of Bramber* (1830) p360
2. Pigot *op cit*; Cartwright *op cit* pp334-35; Arthur Young, *General View of the Agriculture of the County of Sussex* (1813) p418, Frederic Shoberl, *The Beauties of England and Wales Vol xiv Sussex* (1813) pp96-97.
3. Wm. III c15; Owen Manning & William Bray, *The History and Antiquities of the County of Surrey Vol III* (1814) Appendix p1
4. 28 Geo II c28.
5. Young *op cit* p417.
6. 27 Geo II c45
7. 4 Geo iii c 42
8. 32 Geo iii c115
9. 49 Geo iii c 5
10. 11 Geo IV c 6
11. 51 Geo iii c 80
12. 52 Geo iii c 26
13. 58 Geo iii c 69
14. 4 Geo IV c 42
15. Pigot (1839) p257.
16. *Sussex Notes and Queries* Vol 13 p114.
17. Geo II c 45
18. Young *op cit* p418.
19. T.E.C. Walker, 'Turnpikes to Guildford and Horsham' *Proceedings of the Leatherhead & District Local History Society* 2(10) 1966 p287
20. A tollgate at Warnham is recorded in *VCH. Sussex Vol VI Part 2* (1986) p205 but the evidence for its existence cannot be established from the footnote references given.
21. *Sussex Weekly Advertiser* 17 July 1820.
22. Walker *op cit* pp287-88; Alan A. Jackson (ed), *Dorking: A Surrey Market Town Through Twenty Centuries* (Dorking 1991) pp39-40.
23. BPP. *Appendix to the Report of the Commissioners of*

- Inquiry into the State of the Roads in England and Wales* 1840 (280) xxvii 15 p411.
24. Susan Haines, *Horsham: A History* (Chichester 2005) p104
 25. 30 Geo II c60
 26. 39 Geo III c34. For further details see Brian Austen, 'Turnpike Roads to Arundel, Worthing and Littlehampton' *Sussex Industrial History* 36 (2006) p13.
 27. Geo III c12.
 28. G.D. Johnson, 'The Latter Days of the Alfold Bars and Newbridge Turnpike Road', *Sussex Notes & Queries* X p125.
 29. 38 & 39 Vict c144.
 30. Johnson *op cit* X No 5 p103.
 31. WSRO TD/W149.
 32. C.H. Bayley, *Ifold, Loxwood and Plaistow – Forgotten Border Villages* (Ifold 1988) p73.
 33. Johnson *op cit* X No 5 pp103-05.
 34. WSRO Add Mss 5159, 113-14.
 35. Richard Williams, 'Milestone at Bramley', *Surrey Industrial History Group Newsletter* 14 (Aug 1988) p8.
 36. Johnson *op cit* X pp125-27.
 37. WSRO Add Mss 28034; 49 Geo III c12.
 38. 10 Geo IV c6.
 39. 36-37 Vict c90.
 40. Pigot *op cit* p259.
 41. BPP *Abstract of Returns from the Clerks of the Peace Respecting Turnpike Road Trusts for the Year 1829(1833)* pp240-41.
 42. BPP *Appendix to the Report of the Commissioners of Inquiry into the State of the Roads in England and Wales* (1840) pp421-27.
 43. BPP *Turnpike Trusts – County Reports of the Secretary of State No 3 Sussex* (1851) Appendix 1 p11
 44. WSRO TD/W103.
 45. WSRO PAR176/21/5.
 46. WSRO Slinfold Album 7833-7981 PH 7955. A drawing of this tollhouse by R. Green of Horsham was published in the *West Sussex Gazette*, exact date unknown but c1926-30.
 47. WSRO TD/W102
 48. Alan Siney, *Dunsfold Before the Airfield* (1992) pp31-32.
 49. *Sussex Weekly Advertiser* 24 Aug 1820.
 50. Siney *op cit* pp35-38.
 51. David Rose, *Guildford & Villages: Then and Now* (Derby 2003)
 52. Surveyed in 1970 by Geoff Smith and Brian Austen.
 53. Williams *op cit* p8.
 54. 51 Geo III c80.
 55. Brian Austen, 'Turnpike Roads to Arundel, Worthing and Littlehampton' *Sussex Industrial History* 36 (2006) p13.
 56. WSRO Petworth 8990.
 57. WSRO Petworth 6354
 58. 39-40 Vict c39.
 59. WSRO Petworth 6354
 60. WSRO TD/W135.
 61. Survey by Brian Austen at the time with additional information by Geoff Smith.
 62. WSRO TD/W13; Petworth 8972.
 63. WSRO Petworth 5551, 8930, 8939.
 64. 52 Geo III c26.
 65. BPP *Appendix to the Report of the Commissioners for Inquiring into the State of the Roads in England and Wales* (1840)
 66. 28 & 29 Vict c107.
 67. G. D. Johnston, 'Inscriptions on Sussex Bridges', *Sussex Notes & Queries* XVII No 7 May 1971 p217
 68. 59 Geo III c69; BPP *Appendix to the Report of the Commissioners of Inquiry into the State of the Roads in England and Wales* (1840) p411.
 69. Chris Budgen, 'The Bramley and Rudgwick Turnpike Trust' *Surrey Archaeological Collections* Vol 81 (1992) pp97-102.
 70. Photograph in Michael Miller, *Around Cranleigh* (Stroud 1995) p47.
 71. Budgen *op cit* pp 97-98, 101-02.
 72. Pigot 1839.
 73. 8 & 9 Wm III c15.
 74. Pigot 1839.
 75. John Playford, 'A Sussex Tour in 1777 – Made by Francis Grosse, the Antiquary', *Sussex County Magazine* Vol 11 No 8 Nov 1934 p703.
 76. SCM Vol 9 No 5 May 1935 p330
 77. 4 Geo IV c42.
 78. Thomas Walker Horsfield, *The History, Antiquities and Topography of the County of Sussex* Vol I (Lewes 1835) p97.
 79. BPP *County Reports to the Secretary of State* 3 (1852) p11.
 80. 36 & 37 Vict c90.
 81. WSRO TD/W68 (1844); which shows the building as rectangular.
 82. William Albery, *A Millennium of Facts in the History of Horsham and Sussex* (1947) p619. Another drawing of this tollhouse appears in Frank Holmes, *In and About Old Horsham* (1987) p71, but may well have been based on Albery's drawing.
 83. WSRO TD/W156; Wayfarer Denman, *Crawley Revisited* (Crawley 1993) p122

THE COWFOLD AND HENFIELD TURNPIKE TRUST 1771-1877

PART 2—THE BRANCH ROAD AND LATER HISTORY

John D. R. Townsend

When established, the Trust controlled the road from Henfield through Cowfold terminating at Handcross where it made a junction with the Brighton and Cuckfield and West Grinstead Trust which connected north of Crawley with the Reigate Trust and access to London. A short branch from Corner House, Shermanbury, to Partridge Green gave access to the Horsham and Steyning Trust. However, in 1792, the Cowfold and Henfield Trust received powers to extend their road northwards to gain direct access to Horsham. This extension of just over four miles was, from the renewal Act of 1830, administered separately from the main line of the Trust. It was referred to as the 'Branch Road', the original line being distinguished as the 'Old Road'. The Act of 1830 also authorised the construction of a short connecting road from Lower Beeding westwards to meet the Branch Road¹. Separate minute books and financial accounts were maintained by the Branch and the Old lines².

The Branch Road

Branch meetings took place at the *King's Head* in Horsham. John Naldrett's bill (fig. 1) is for the use of rooms only³, but the trustees undoubtedly enjoyed the generous fare of the inn as did their colleagues at the *Red Lion*, Cowfold, on the original (old) line of road.

Despite the separate administrations, there was some overlap of functions. For example, Thomas Coppard was Clerk for the Branch Road in 1830, and had very likely been appointed in 1822 when he began his long service with the Old Road. He does not appear to have received a second salary, for none is recorded in the Branch accounts for 1830-1831 and for 1857⁴. Likewise William Kinchin was Surveyor in 1830. He was replaced by Daniel Linfield, but was re-appointed in 1845 with an annual salary of £10, increased to £15 in 1846. The Treasurer of both Roads in 1830 was Rev Richard Constable⁵. He paid the trustees of the Old Road the sum due to them from the previous financial arrangement. (See fig. 2) Robert Aldridge succeeded

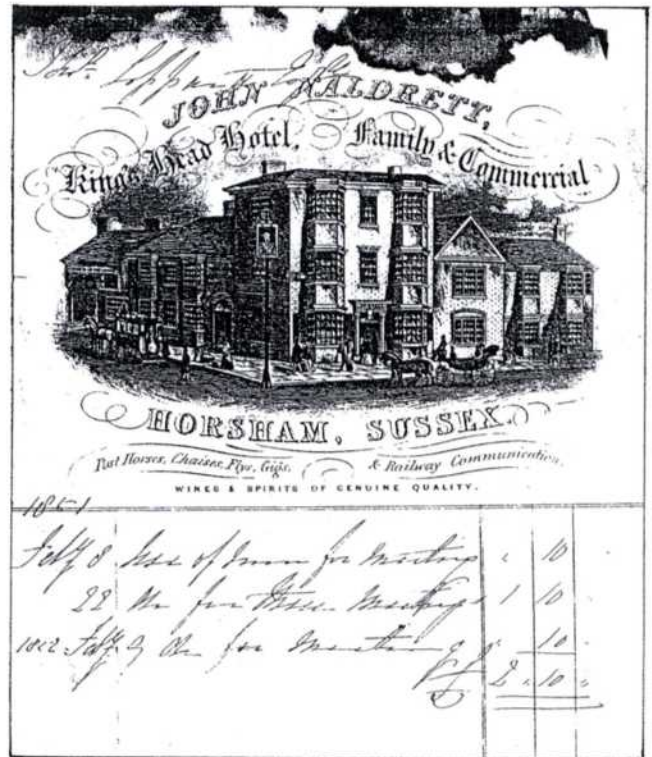

Fig.1 Invoice dated 1851-52 for meeting of the Trustees of the Branch Road

him in 1831 for the Branch Road and was in turn replaced by William Sharp, 1841-1845. Then the London and County Bank, Horsham, took over.

The trustees appointed under the terms of the 1830 Act administered both Roads. Those who attended meetings at the *Red Lion* about the Old Road came generally from the parishes served by or situated near that Road (and from Brighton). Those interested in the Branch Road were normally from Horsham and district. An undated mailing list divides the trustees into three groups: Old Road, Branch Road and Old and Branch Road⁶. Occasionally a name like William Borrer or J. L. W. Dennett, associated usually with the one Road, appears in the Minutes of the other. General Annual Meetings were held at first in the autumn, but from 1834 early in the year.

Attendance at all meetings was sparse. Some had to be abandoned for lack of numbers. By contrast the nineteen present at the *King's Head* in March 1851 set a record for the Trust.

Income for expenditure on the Branch Road was raised almost entirely by tolls, either through a lessee (in the year 1830-1831 Philip Chasemore bid £206, see fig. 2) or directly by the Trust (in 1857 £209 17s 1d, £209.85)⁷. They were collected at the one toll-gate, known as Monks Gate, but in Lower Beeding and not in the settlement called Monks Gate in Nuthurst.

A General Statement

OF THE

INCOME AND EXPENDITURE OF THE COWFOLD AND HENFIELD BRANCH TURNPIKE ROAD,

Between the 29th day of September, 1830, and the 6th day of September, 1831.

EXPENDITURE.				INCOME.			
To Surveyor's account of Day Labour for the maintenance of the Road in the above period....	91	15	4½	By Amount of Rent received from the Lessee of the Tolls between the 29th day of September 1830, and the 6th day of September 1831, being (including Two Months Rent paid in advance) 12 Months Rent up to the 29th September 1831.....	206	0	0
To ditto for Team Labour.....	09	17	6	By Cash received for the scrapings, &c. of the Road.....	2	10	0
To ditto for repairs and maintenance of Buildings, Gates, Bridges, Tools, &c. including new Toll Board.....	22	15	6				
To ditto for Land purchased or damage done in digging Stone.....	14	13	3				
To Cash paid Surveyor's Salary, including his Workmanship.....	33	19	0				
To Clerk's Bill, including Printing, Advertising, and Stationery.....	1	1	16				
To amount due to the Trustees of the old Turnpike Road, for the maintenance of the Branch Road prior to the separation of the Accounts.....	25	15	4				
	270	12	2½		208	10	0

General Statement of Debts and Credits

An Account of the Amount of Debt bearing Interest	0	0	0	By Cash in Treasurer's hands.....	82	15	7½
An Account of Interest due.....	0	0	0				
An Account of Floating Debt.....	144	17	10				
	144	17	10		82	15	7½

Fig.2 Statement of Income and Expenditure, September 1830—September 1831

Scrapings and parings added a small amount to the funds, £2 18s 0d (£2.90) in 1857.

Each year the problem of letting the tolls arose. There were no bidders in 1831 despite two attempts to attract them. Sometimes bids were put in privately after the public auction had failed. However, the offer from those who became lessees was never below £200 a year, a figure which compares very favourably with the income produced by the four gates on the Old Road. Even so, the trustees struggled to find the money to maintain the road. In 1837 the accounts showed a balance of £6 11s 8½d (£6.58), but unpaid bills amounted to £100 13s 8½d (£100.68). They reduced the tolls in 1835 to stimulate traffic. They applied to the Justices in 1841 for permission to seek contributions from the three parishes served by the Road, but the Justices refused because the trustees were not taking the full tolls granted by the 1830 Act. The trustees then increased the tolls slightly. They also limited the wages of the roadmen to 10s (50p) per week. A new debenture of £100 (apparently the first since the early days of the Trust) earning interest at 5% was issued to Miss Hannah Tuppen in 1846. A committee was set up to

find ways of reducing expenses. All these measures helped to keep the Trust going, if with difficulty. In 1868 the balance on the accounts dropped to £3 19s 2d (£3.95)

The Surveyor warned in 1851 that the road needed a "greater amount of repairs ... than hitherto, it being in many places in a weak state". Otherwise, perhaps surprisingly, he nearly always reported favourably: "tolerable" (1853), "good" (for most of the 1860s), "very good" (1869). As on the Old Road, flints were used for maintenance, perhaps supplemented with some stone. The wages of the men "working in the stone pit" (at Mannings Heath?) were fixed at "1s (£0.05) per square" in 1844. Among the suppliers of flints was James Batterbee. He sold the Trust 255 tons in 1867. How he transported them from the coast is not recorded, but very likely by rail to Horsham Station.

Apart from routine maintenance the road needed little work. William Vinall of Cowfold rebuilt "the Bulged part of the Broken Wall" at Birchen Bridge in 1846⁸. He offered to reduce costs by using old bricks from the recently demolished Horsham Gaol, but the trustees ordered new ones. At the same time he repaired the "Bridge or Culvert Drain" at Hornbrook

Hill. The money received from Miss Hannah Tuppen helped to meet his bill of £59. In 1857 an additional apron (or platform below a sluice) "for the fall of the Water" was constructed at Birchen Bridge, presumably to serve the water-mill there. Finally the Surveyor was asked to improve the hill between the Bridge and the Dun Horse in Mannings Heath by laying pipes in the water table by the sides of the road. Even in recent years this stretch has always suffered from excess surface water after heavy rain.

The Branch Road was 4 miles 0 furlongs 165 yards long⁹. Despite this precision, disputes arose between the trustees and the Highways Board in Horsham over responsibility for the western section of the road: about four hundred yards between the Queen's Head and the Tanyard. In 1839 the Clerk of the Board reported that the ditch near the Tanyard was in a dangerous state and should be covered over. The Board would provide all the stone if the trustees would convey it and complete the work. The latter refused to accept any responsibility for the ditch, but said they would examine how far they were liable to repair "such parts of the road as lies within or contiguous" to Horsham. An agreement was made with the Board's Surveyor that he would maintain the disputed stretch, but the trustees were dissatisfied with his work and complained frequently to the Board.

A topic for discussion from 1841 was the location of the toll-house. For unstated reasons the trustees wanted to remove "the Turnpike Gate Toll House and Appurtenances now standing on or near to Monks Common" to some other place on the Branch Road. Their first choice was a site near the Dun Horse. Then (1851) they considered a position nearer Horsham, between the Tanyard and the road leading to Doomsday Green. This proposal being defeated by eleven votes to five, they let the matter drop. Indeed, they spent £30 on repairs to the toll-house in 1858 and made the Collector's home more comfortable by providing a shed for his wood and coals. When the Branch Trust was wound up, the toll-house was not demolished. John Aldridge bought it, only to sell it ("late a Toll house and Garden") with other property in 1875¹⁰.

The Benefit brought by the Turnpike

A parliamentary report published in 1852 noted that "in 1838, Turnpike Roads were the chief means of communication throughout the kingdom for the

transit of goods and passengers; much expense and skill had been bestowed in adapting the roads to the increased traffic of goods, and the more speedy passage of the mails and the stage coaches"¹¹. This favourable judgement on the nation's main roads is shared by writers on Sussex. In 1813 Arthur Young thought that "The turnpike roads in Sussex are generally well enough executed" and that the roads from the south of the county to London "are very good"¹². Howard Dudley wrote in 1836 that Horsham was "remarkable for the excellent state of its turnpike roads"¹³. Presumably he was thinking about all the roads that met at Horsham, including the Branch Road and the Old Road beyond. Even as late as 1868, Dorothea E. Hurst reported, "The turnpike roads through Horsham have for many years been remarkably good"¹⁴.

Wealden farmers benefitted from better communications¹⁵. Markets were open to them at all times, not just in summer. Their produce could be moved in large quantities. Marl and lime, essential for improving the heavy Weald clay, could more easily be transported. Local newspapers with market reports circulated more widely. When the Gratwick estate in Cowfold was auctioned in 1845 an important selling point was, "The Brighton Turnpike Road forms the western limit of the property"; and there was easy access one mile away at Cowfold to another turnpike road, the 'East and West Sussex Junction Road'¹⁶. Also in Cowfold was Goresdean (or Gosden) water-mill. Offered for sale in 1774, its merits included being "conveniently situate for Trade, by Turnpike-Roads, with Horsham, Dorking, Crawley and Reigate"¹⁷.

Carriers prospered. Henry Taylor of Cowfold operated a service from London to Brighton through Horsham every Tuesday and Friday, returning on Wednesday and Saturday. David Caffin of Henfield ran a wagon every Monday to the *George Inn*, Borough; and the van of William Rich, also of Henfield, travelled to and from London on Mondays, Thursdays and Saturdays¹⁸. The last named offered a lighter and faster service with his 'flying wagon' than did his competitors with their more capacious and cumbersome stage-wagons.

The distribution of letters as well as goods was improved. No mail coaches ran along the Old or Branch Roads. Their bags for local delivery were transferred to mail carts which delivered to post towns where further sorting took place. In his *A new and accurate description of all the direct and principal*

cross roads in Great Britain (1808), Daniel Paterson named Henfield as a post town. Letters from London arrived at 9 am and were despatched at 3 pm¹⁹. Steyning was another post town, and in 1845 delivered letters to Shermanbury, along the Old Road between West Grinstead and Corner House²⁰.

Travellers in coaches and carriages and on horse moved more quickly and more freely, even by night. Nathaniel Paine Blaker remembered seeing as a boy in Sussex the coaches at night, "when their approach was announced by a bugle, and they were lighted up with a number of lamps, and seeming to bear down upon you like a big ball of fire"²¹. By 1800 a regular coach service operated between Brighton and London through Henfield: northbound on Mondays, Wednesdays and Fridays, returning on the following days. A coach ran from Brighton to Oxford via Henfield and Horsham on Tuesdays, Thursdays and Saturdays, and to Windsor on the previous days²². The Prince Regent "often" passed through Henfield. His destination would have been Windsor rather than London, for which the more direct road through Cuckfield and Crawley would be preferable. An obelisk in the centre of Cranleigh, Surrey, with directions and mileages suggests the route he took: on one side, Rudgwick, Horsham, Brighton: on another, Womersley, Guildford, Windsor²³. De Candolle tells the story of Jimmy, a post-boy at the George in Henfield, who earned 7s 6d (£0.38) from the Prince by driving him to the Black Horse in Horsham in fifty minutes, ten minutes less than the time the Prince stipulated for the ten-mile journey²⁴. Henfield, ten miles from Brighton, was the first stop for changing horses; Horsham, the next²⁵. Apart from the *George*, coaches called at the *White Hart*²⁶. Both inns enjoyed "considerable prosperity" in coaching days, thanks to the Old Road²⁷.

Road books catered for travellers, giving them directions and information about their journey. James Edwards, *Companion from London to Brighthelmston* (1801) includes a survey of the Henfield road. He describes the first section of the Branch Road from Horsham:

"On the left ... stands the County Gaol .

On the same side is the *Queen's Head* public house.
Enter Horsham Common"

Another road book by Daniel Paterson, already mentioned, is more succinct than Edwards's. He refers without much comment to places and to properties and their owners. He gives mileages from

Westminster Bridge, London, and between towns and villages. He indicates the market towns, like Horsham, and the places which supply post-horses, like the *George*, Henfield. A third road book is Attree's *Topography of Brighton; and, Picture of the Roads from thence to the Metropolis* (1809). He describes the road through Henfield to Horsham, with more comment than Paterson, but without Edwards's detailed directions.

Not all users of the Roads were passing through. Some had settled by or near them. The number of houses in Henfield increased by half between 1811 and 1821 'presumably' because of the turnpiking of the roads through the parish. People of means chose the village for residence and retirement²⁸. Though it had nothing "of curiosity or interest sufficient to delay the tourist in his progress", it was "pleasantly situated" in an area "replete with rural beauty"²⁹. The further north one travelled along the Old Road towards higher ground and St. Leonard's Forest the more attractive the countryside became. At the junction of the Old and Branch Roads, Charles George Beauclerk Esq, the proprietor of the south part of the Forest, built a "neat and commodious edifice". This was St. Leonard's Lodge, mentioned by Attree (1809) as "recently built". Leonard's now occupies the site. Further south, in Cowfold, not far from the turnpike road, James White Esq. "has created a convenient and pleasantly situated mansion, called Woldringfold"³⁰. Whoever bought the Gratwick estate in 1845 would have enjoyed not only the economic advantage of the turnpike roads nearby, but also "an extensive panoramic view, terminating in the South by the famed Sussex Downs ... The fact of Four Gentlemen's Seats having been very recently built in the immediate vicinity will testify to the eligible character of the Locality"³¹. The Old and Branch Roads had opened up an attractive part of Sussex for settlement. Their influence continued after the end of the Trust. Faster travel enabled the urban gentry to acquire second homes in the countryside or in favoured locations along the coast. Commuting became possible. In the 1820s William Cobbett attacked the "Great parcels of stock-jobbers" living in Brighton, who "(skipped) backward and forward on the coaches" every day to 'Change Alley' in London³². That was in the heyday of coaching. Soon those stock-jobbers, and many others who lived in one place and worked in another, would prefer to use a much faster and cheaper mode of transport.

The Arrival of the Road Locomotive

From 1850 William Kinchin gave his annual Surveyor's report on the condition of the Old Road to the General Annual Meeting. His usual assessment was that it was in "general tolerably good" or "in a fair state of repair". Between 1858 and 1864 the road was in good, or very good, order³³. He sometimes added that a few more tons of flints than had been budgeted for would be "advisable" or "desirable". However, by 1873 the situation had changed. The stability of the road and bridges was threatened by the "the continued passing and repassing of heavy Steam Cultivators"³⁴. The Surveyor reported in January 1875 that the road was "in a weak state between Corner House and Partridge Green and between Crouch Hill Gate and Henfield". The latter section had been damaged by "Steam ploughs [which] have cut the Road up very much". He had no materials left for repairs. He was granted an extra 370 tons of flints³⁵. The damage was compounded when the locomotives pulled heavy loads. As appears below, much stone was being transported at that time. The road was not strong enough for such traffic³⁶. The position was so serious that two trustees, William Borrer and Richard Hoper, called a special meeting in May 1875 "To consider the present state of the Road & what steps, if any, it may be necessary to take to prevent its destruction"³⁷. Steam had arrived. A road designed for landaus, berlins, farm wagons and carts could not cope with these new vehicles.

The use of engines on roads was regulated by the Locomotive Acts of 1861 (24 & 25 Vic c.70) and 1865 (28 & 29 Vic c. 83). The surveyor's consent was needed for any locomotive more than seven feet in width and twelve tons in weight to be used on a road. The weight of the engine, and whether it was drawing or not, determined the width of wheels permitted; the load carried by a trailer was not to exceed four tons for each pair of wheels; and the use of bridges was restricted. Without the surveyor's permission, it was unlawful for a locomotive to be driven over a bridge "on which a conspicuous Notice has been placed ... that the Bridge is insufficient to carry Weights beyond the ordinary Traffic of the District". In the event of a dispute the Secretary of State could appoint an arbiter. The Act of 1865 contained the famous section limiting the speed of an engine to four mph and requiring a man with a red flag to walk before it.

Bridges were particularly vulnerable. Mr Cooper's engine had damaged Bull's Bridge in Cowfold and after some argument with the Clerk he agreed to repair it and not to use the road any more for "the drawing of stone". Furthermore, he said, he had returned to the makers the wagons he had used³⁸. The trustees then ordered at their special meeting in May 1875 that notices allowed under the Locomotive Acts be posted on all bridges and arches in their care³⁹.

The trustees' dispute with Cornelius Wales and Albert Agate, locomotive owners, was not so easily settled. In 1877 they were prosecuted for using engines with wheels less than nine inches in width. The Clerk consulted Mr Wollaston of Hurstpierpoint, civil engineer, who accompanied him to Cowfold and Lower Beeding to examine the road used by Wales and Agate and to take "sketch & plans of the Locomotive Wheels". Mrs Stepney, the Collector at the Crab Tree Gate, was asked to attend the Bench in Horsham with her book showing the number of times the locomotives had passed through her Gate. Each defendant was fined £1 and agreed not to use his engine until the wheels were altered. Wales's engine was examined in Partridge Green. Its driving wheels had had pieces of iron "bolted in between the former spaces in the Tire to the width of 9 in[ches]" (therefore legal), but the unaltered front wheels still had "a raised band around the same 5 in[ches] wide & ½ in[ch] in thickness". Presumably Agate, too, had modified his engine. Both were again brought before the Bench in June 1877 and discharged on payment of £26 7s 8d (£26.38) costs and on "agreeing not to use their locomotives on the road except for agricultural purposes". It appears they had been drawing stone, for which the narrow front wheels were not permissible, but were allowed for other work⁴⁰.

For whom were Messrs Cooper, Wales and Agate working? In 1873 William P. Boxall (a trustee) sold an estate formerly called Picknoll, and thereafter Parkminster, to the Carthusian Order of monks⁴¹. It lay beside the road between Cowfold and Shermanbury. There the Order built St. Hugh's Monastery. It consumed vast quantities of materials⁴². Every fortnight 60,000 bricks were made in four kilns on the site. Ordinary stone, dug locally, was brought in. It came almost certainly from quarries east of Mannings Heath, where a stone merchant was recorded in 1874⁴³; and/or from Lower Beeding⁴⁴. The sale particulars, 1878, for the St

Leonard's Forest Estate in Lower Beeding and Nuthurst mention "valuable Quarries of Stone". One was situated just to the north-east of Lower Beeding church, for example⁴⁵. The builders also wanted freestone from Bath, which would have been transported by rail to Partridge Green. Cooper, needing to cross Bull's Bridge, and Wales and Agate, travelling through Lower Beeding and Cowfold, were undoubtedly drawing stone from the north to the building site; and Wales, whose engine was examined at Partridge Green, from the station in the south.

There was a fourth locomotive – 'the monks' engine' – which belonged to Rev Fortune Duroux, apparently the Father Superior of the community⁴⁶. After the 'retirement' of Cooper, Wales and Agate from hauling, his was perhaps the only machine serving the builders. In carrying freestone from Partridge Green Station to Parkminster via Corner House, it crossed a bridge over a narrow unnamed stream dividing West Grinstead and Shermanbury. The use of this bridge, protected by the Order of May 1875, caused bitter controversy between the trustees and the monks, as the trustees deemed it insufficient to carry the weight of the locomotive.

It began with a letter of 16 December 1875 from Thomas Stepney at the Crab Tree Gate to the Surveyor. He wrote that the monks' engine had run into Partridge Green Station for the first time on the day before, had been twice "today" and "believe they are going tomorrow"⁴⁷. A message from James Batterbee to the Clerk confirmed the report and added that the monks intended to make frequent such journeys⁴⁸. After consulting William Borrer, a trustee, the Clerk decided on his own initiative to serve a notice on the monks not to use that road⁴⁹. To call a full trustees' meeting, he believed, would cause delay and serious damage.

In the prolonged argument between the trustees and the monks and their solicitors in London, the trustees were adamant that they had full powers of prohibition. Their opponents insisted by letter and telegram⁵⁰ that the bridge at the centre of the dispute was strong enough because their locomotive had twice passed over it without causing damage; and that they would apply to the Home Office for an arbitrator. Colonel Hutchinson, engineer, was appointed. In February 1876 he ruled against the monks. Nevertheless, they continued to run the offending locomotive, hauling stone, as Knight, a roadman, reported in May 1877. The trustees

instructed the Clerk to proceed against them⁵¹. But nothing further seems to have been done. Perhaps the knowledge that the Trust would expire in six months time weakened the trustees' resolve. It would then be the responsibility of other authorities to deal with the recalcitrant monks⁵².

The Demise of the Trust

By the 1830s the weaknesses of the turnpike system had become apparent. A report in 1840 identified some "evils":

- the number of Trusts
- the number "and frequently unjust positions" of toll-gates
- the high rates of toll⁵³
- incompetent surveyors.

The way forward, the author concluded, was the consolidation of Trusts⁵⁴. A Bill to effect this had already been introduced in 1837 and withdrawn after strong opposition. The reaction of C. M. Boxall was vehement. "The end will be ... a Superior paid Board in London whereby the present Trustees & Clerks & Surveyors ... will be mere tools & Helots of some half doz well paid briefless Barristers in London ... or Ex MPs ... the practical discretion of our Ancestors [is] by the Blockheads of the day...put to scorn as old Rubbish."

An undated plan of reform by an unnamed person or body advocated centralising the management of the roads in either county or district boards. It proposed in essence to set up "a General County Turnpike on the Borders of each County" on each turnpike road, all intermediate turnpikes being abolished. The toll would be a flat 2d per mile for the journey the traveller declared he intended to take. He would receive a ticket to be delivered with payment to an official at the place of arrival.⁵⁶ Despite its obvious flaws, this scheme addressed the multiplicity of toll-gates which hampered the free flow of traffic, but it might not have done much to reduce the expense of a journey.

In the end, the Trusts were not reformed. Their fate was settled for them. In 1841 a railway line joined London and Brighton via Three Bridges and Haywards Heath; in 1848, Three Bridges and Horsham; and in 1861, Horsham and Shoreham, via West Grinstead, Partridge Green and Henfield⁵⁷. The railways provided faster and cheaper journeys for passengers, and were far superior to the carriers for moving goods. A traveller from Brighton to

Horsham at about 10 mph by road would face delays at intermediate gates and at Henfield for a change of horses. In 1841 by rail he would travel at about 30-40 mph to Three Bridges and could enjoy a journey with few stops; at that station he could take the railroad coach to the *King's Head* in Horsham for the final eight miles⁵⁸ or, after 1848, the train. The Cowfold and Henfield Trust was not at first as adversely affected as those Trusts near railways. On the direct route between London and Brighton "the extensive traffic of passengers, with scarcely an exception, was transferred ... to the railway" by 1852. Even so, the toll income from the Old Road, more distant, fell sharply:

1834 £ 655 0s 0d

1842 £574 19s 1d

1850 £374 13s 7d

The receipts from the Branch Road showed a similar, but less marked, reduction. Fortunately, the Roads having earlier been put into good order, the sums for repairs declined. For the Old Road⁵⁹:

1842 £418 8s 3d

1850 £242 9s 5d

But the difficulties facing the Treasurers of the Roads remained acute.

The Local Acts extending the 'life' of the Old Road (11 Geo IV c. 104) and of the Branch Road (11 Geo IV c. 105) were due to expire in 1862⁶⁰. However, they could be prolonged under the Annual Turnpike Continuance Acts. By 1868 the trustees of the Branch Road were debating the issue. They heard from the Surveyor that the road was in good condition, and from the Treasurer that the accounts were in credit, even if only just. They decided in May that the Clerk should write to the Secretary of State that "the further continuance of the Trust is desirable" for the moment⁶¹. They soon changed their minds. A letter from Whitehall in March 1869 announced that "in conformity with the wishes of the Trustees" the Branch Trust would be abolished on 1 November 1869, "unless some of the Inhabitants of Nuthurst appear before the Select Committee and obtain an Extension of the term" ⁶². This apparently did not happen.

The trustees wound up the Trust in October. They compensated the Clerk with £25 and the Surveyor with £15. They apportioned the balance of the Trust fund and the stock of flints, according to mileage,

between the parishes now responsible for the road⁶³. They conveyed Monks Gate toll-house and garden to John Aldridge of St Leonard's, Lower Beeding for a consideration of £35⁶⁴. They planned another meeting for December 1869, but there is no record of its having taken place.

The Old Road lasted a little longer. At the Red Lion in December 1876, the trustees considered a notice from the Local Government Board (since 1872 responsible for turnpike trusts in place of the Home Office⁶⁵) that the Trust would be terminated in November 1877. They decided not to apply for the continuance of the Local Act. The Trust expired on 1 November. Further meetings were held to settle affairs. In December William Wood, Surveyor, was instructed to dispose of the tools used on the road; and John Plumer of Horsham, surveyor, was asked to inspect and value the four toll-houses. His report was ready in January⁶⁶. The trustees had also to dispose of the toll-houses and premises⁶⁷:

- Crouch Hill to James Scott of Chestham Park, Henfield, for £70

- the garden and pond opposite to James B Leigh of Brighton, for £5

- Corner House to Percy S Godman of Shermanbury Grange, Shermanbury, for £45

- the toll-house site at Crab Tree to Richard Hoper of Cowfold, for £32

- Truckers Hatch to Capt. Warden Sergisson of Cuckfield Park, for £60

The Crab Tree toll-house had been demolished before the conveyancing took place. The others were used for some years longer. De Candole in 1947 wrote that the Corner House was "still standing", and that the Crouch Hill house was inhabited "till recent years"⁶⁸.

The parishes served by the former Old Road were soon relieved of the full cost of its maintenance. By the Highways and Locomotives Amendment Act of 1878, roads disturnpiked after 31 December 1870 were designated 'main roads'. Presumably the Branch Road, closed as a turnpike in 1869, was so treated as an extension of the Old Road. Half the money for their upkeep came from a rate levied by the county authority, and the rest from a rate levied by the parish or highway district (groups of parishes). The Local Government Act of 1888 transferred responsibility for main roads entirely to the newly-established county councils⁶⁹.

References

1. John D.R. Townsend, 'The Cowfold and Henfield Trust - Part 1- The Old Road', *Sussex Industrial History* 37 (2007) pp.29-40
2. WSRO Add Ms 9242 Minute book for the Branch Road, the main source of information for this section
3. WSRO Add Ms 9213
4. WSRO Add Ms 9210
5. WSRO Add Ms 9156, 9225
6. WSRO Add Ms 9165
7. WSRO Add Ms 9210
8. WSRO Add Ms 9237
9. Brighton History Centre, S040 SP vol117, County Report 1852
10. Horsham Museum Ms 3188
11. Brighton History Centre S040 SP vol. 17
12. Arthur Young, *General View of the Agriculture of the County of Sussex* (1813) p.416
13. Howard Dudley, *History and Antiquities of Horsham* (1836) p.71
14. Dorothea E. Hurst, *Horsham: its History and Antiquities* (1868)
15. Eric Pawson, *Transport and Economy, The Turnpike Roads of Eighteenth Century Britain* (1977) p.152
16. Horsham Museum SP 71
17. *Sussex Weekly Advertiser* 18 July 1774
18. *Post Office Directory: Sussex* 1845
19. *A New and Accurate Description of all the Direct and Principal Cross Roads in England and Wales* (14th edn 1808) p.33
20. *Post Office Directory: Sussex* 1845
21. H. de Candole, *The Story of Henfield* (1947)
22. William C. A. Blew, *Brighton and its Coaches: A History of the London and Brighton Road* (1894)
23. Information from Lionel Joseph, Forest Green, Surrey
24. de Candole *op cit*
25. Blew *op cit*
26. *Pigot and Co's National and Commercial Directory* 1839
27. De Candole *op cit*
28. T. P. Hudson, *Victoria County History: Sussex Vol. VI Pt 3, Henfield* (1987)
29. *Pigot* 1839
30. T. W. Horsfield, *The History, Antiquities and Topography of the County of Sussex Vol 2* (Lewes 1835) p.261
31. Horsham Museum SP 71
32. Pawson *op cit* p.332
33. WSRO Add Ms 9157
34. WSRO Add Ms 9239
35. WSRO Add Ms 9157
36. WSRO Add Ms 9234
37. WSRO Add Ms 9239
38. WSRO Add Ms 9213
39. WSRO Add Ms 9157
40. WSRO Add Ms 9234
41. VCH Vol. VI Pt 3 Cowfold (1987)
42. George Dysart, 'England's Great Charterhouse', *Sussex County Magazine* Vol.27 (1953)
43. VCH Vol. VI Pt 3 Nuthurst (1987)
44. VCH Vol. VI Pt 3 Lower Beeding (1987)
45. Horsham Museum SP 203
46. WSRO Add MS 9234
47. WSRO Add Ms 9239
48. WSRO Add Ms 9213
49. WSRO Add Ms 9234
50. In May 1871 Thomas Coppard received a letter from the Postmaster General about the intention "to erect a line of Telegraph from Brighton to Henfield etc". He asked permission to set up poles and wires along the turnpike road to link the post offices at Henfield and Cowfold to the system (WSRO Add Ms 9160). The trustees assented (WSRO Add Ms 9157).
51. WSRO Add Ms 9234
52. Local legend states that the monks avoided most of the turnpike road, the Corner House Gate and the disputed bridge by sending their locomotive westwards from Parkminster across their own land to Littleworth Lane, the parish road entering Partridge Green from the north. If true, this story may explain the inaction of the trustees after May 1877.
53. The owner of Terry's Cross near Henfield, had to pay 7s 6d (£0.38) in 'gates' to take a party from his house to a ball in Brighton (de Candole *op cit*)
54. WSRO Add Ms 9153
55. WSRO Add Ms 9237
56. WSRO Add Ms 9226, 9237
57. Kim Leslie and Brian Short, *An Historical Atlas of Sussex* (1999) p80
58. *Post Office Directory: Sussex* 1845
59. Brighton History Centre, S040 SP vol17 County Report 1852
60. *Ibid*
61. WSRO Add Ms 9242
62. WSRO Add Ms 9205
63. WSRO Add Ms 9242
64. Horsham Museum Ms 3159
65. WSRO Add Ms 9239
66. WSRO Add Ms 9157
67. WSRO Add Ms 9166
68. De Candole *op cit*
69. W. J. Reader, *Macadam, The Macadam family and the Turnpike Roads 1798-1861* (1980) pp 200-03

CVA AT COOMBE ROAD, BRIGHTON

Peter Groves

In the spring of 1917, the question of training soldiers disabled in the First World War arose. As a result of a successful pilot scheme, work started in 1918 to build a special factory in Coombe Road, Brighton, opposite Preston Barracks. The factory was known as the Bernard Oppenheimer Diamond Works, and was the backbone of a large undertaking, where the war disabled were trained to polish diamonds. The factory was one of the largest in the Brighton area. In the early days among the names of important visitors were General Smuts, Lord Haig, John Galsworthy and Mr. Horatio Bottomely. Of particular interest was the well-equipped clinic, specially set up to deal with the employees, many of whom had lost limbs and needed specialist treatment¹.

Another very important visitor to the Bernard Oppenheimer Diamond Works, on 1st February 1921, was the Prince of Wales. The Prince had unveiled the Chattri on the Downs behind Brighton prior to his visit to the Diamond Works for disabled men².

The factory was acquired by Hove Machine Tool manufacturer CVA in 1945³. CVA had expanded in

the post-war period, and the old diamond works was one of a number of factories they acquired in the Brighton area in the 1940s and 1950s. CVA used the factory for a number of its departments, and it was home to many projects, fractional horsepower motors, drill chucks, lathe chucks and, surprisingly, domestic appliances.

The domestic appliance venture came about due to the forethought of Eric Aron, who had been the Managing Director of CVA since 1933⁴. Following the Second World War, Eric Aron felt that there would be a war surplus of machine tools, that would flood the market, and he looked to diversify into other markets. Because the likes of Hoover and other domestic appliance manufacturers had been engaged in war work, their production lines had been dismantled. He felt that if he could get into this market quickly, he could obtain a significant portion. Two main products were manufactured at the Coombe Road factory, the CVA Columbine vacuum cleaner and the CVA electric iron. The Company did have some success with these products in the post-war period, however they were based on pre-war designs. As soon as companies like Hoover got back into production, with new designs and new materials, CVA found it difficult to sell their products and production ceased.

For many years CVA had worked with the US machine tool manufacturer, Kearney & Trecker



Fig. 1 CVA, Coombe Road, Brighton c1949

Corporation. In 1957 Kearney & Trecker took a controlling interest in CVA⁵. Kearney & Trecker were innovators of computer-controlled machines, many of which had been involved in the US space programme. Hi-tech machines required highly trained engineers, and CVA had for many years had a good apprenticeship scheme; under Kearney & Trecker the apprentice training school was to have its headquarters in the old diamond works. In the



Fig. 2 Under instruction from Gil Percy, c1969

late 1960s and early 1970s up to 60 apprentices each year spent the second year of their four-year training in the Coombe Road training school, under the watchful eyes of the instructors, Bob Mann, Gil Percy, Tom Muggeridge and Ron Poulton. These instructors had between them well over 100 years of engineering experience to pass on to the young lads.

CVA centralised all operations to Hollingbury in the early 1970s and in 1973 the Coombe Road factory closed and the training facility was moved there. For many years the old diamond works was almost derelict; at one point it was used to store car tyres imported from abroad. More recently, after a complete renovation, the old diamond works is now home to The Big Yellow Self Storage Company.

References

1. *KaTimes* Vol. 2 No1 September 1967
2. *Brighton and Hove, A Second Selection*. Judy Middleton
3. *KaTimes* Vol. 2 No1 September 1967
4. *Sussex Industrial History* No. 23
5. Development of KTM, internal company document printed May 1977, original copy owned by the author.

Figures

1. Directors' Report and Statement of Accounts 1952, authors copy
2. *KaTimes* Vol. 3 No 4 December 1969, authors copy

Digitisation of *Sussex Industrial History*

The Society is considering how to make *Sussex Industrial History* available in electronic format whilst retaining the rights of authors. At present *Sussex Industrial History* makes material available in printed form to the public on a regular basis, with copyright being retained by the authors. Our aim has been that this will add to the knowledge of industrial archaeology and that it will stimulate interest and further research.

Making the articles available in electronic form will reach a wider audience and further promote the Society's work. However, we wish to ensure the rights of authors are protected when we make their material available in this way. We are considering a type of copyright licensing called 'Creative Commons', which is appropriate for organisations like SIAS that seek to share the work of Society members and authors. With this type of licence, the material is available free of charge, whilst retaining some rights for the authors. Specifically, this licence lets others copy, distribute and build upon your work non-commercially, as long as they credit you and licence their new creations under the identical terms. This means that others can download and redistribute your work and produce derivative works based on your work. All new work based on yours will carry the same licence, so any derivatives will also be non-commercial in nature.

We are hoping that all past authors of material in *Sussex Industrial History* will agree to the Society making their work available in this way. If you have contributed any material to *Sussex Industrial History*, please contact the Editor by 1 June 2008 if you have any objections to this proposal or would like further information.

PUBLICATIONS

Previous numbers of *Sussex Industrial History* still available:-

- No. 2 (1971) Dolphin Motors of Shoreham; Lime Kilns in Central Sussex.
 No. 3 (1971/2) Lewes Population 1660-1880; Kingston Malthouse.
 No. 5 (1972/3) East Sussex Milestones; West Brighton Estate; A Bridge for Littlehampton 1821-2.
 No. 17 (1986/7) The Bognor Gas, Light & Coke Company Ltd.; Mineral Transport by the Telfer System (Glynde Aerial Railway); Bricks for the Martello Towers in Sussex; Jesse Pumphery, Millwright.
 No. 18 (1988) See *The Windmills and Millers of Brighton* (revised edition), listed at foot of page.
 No. 19 (1989) Leather Industry; Bignor Park Pump; Lowfield Heath Mill; B.M.R. Gearless Car; Wadhurst Forge.
 No. 21 (1991) Quick's Garage, Handcross; Punnett's Town Wind Saw Mills; Hollingbury Industrial Estate.
 No. 22 (1992) Swiss Gardens, Shoreham; Brighton Brewers; Mill Bibliography; Beddingham Kiln.
 No. 23 (1993) Sussex Limeworks; Mills of Forest Row; Machine Tool Manufacture; Brook House Estate; Mill Authors.
 No. 24 (1994) Pullinger's Mouse Trap Manufactory; Ice Houses; Forest Row Mills; Lewes Old Bank; Lumley Mill; Estate Industry at the Hyde; Slindon Bread Ovens.
 No.25 (1995) Ricardo at Shoreham; Windmill Hill Mill; Portslade Brewery; Brighton General Hospital; Bognor Bus Station; Kidbrooke House Farm; Contents *Sussex Industrial History*.
 No. 26 (1996) Eastbourne Buses; Sussex Lidos; The Sea House Hotel; Bishopstone Tide Mill; Mountfield Gypsum; Uckfield Workhouse; Brighton Oven; Medieval Water Mills.
 No. 27 (1997) Sheffield Park Garden; Brighton Tunbridge Ware Industry; Railway Cutting Excavation; Eastbourne Mills; Tunnels of South Heighton; Sussex Lime Kilns.
 No.28 (1998) Frank Gregory; Brighton Railway Station; Construction of H.M.S. Forward; Bevendean Isolation Hospital, Brighton; Tank Roads on the Downs; Hastings Early Power Supply.
 No.29 (1999) Sussex Windmills and their Restoration.
 No.30 (2000) Balcombe Tunnel; Ditchling Common Workshops; Midhurst Whites; Keymer Brick & Tile.
 No. 32 (2002) Henry Turner, Brickmaker; Crawley Water Company; Tamplins, Brewers; Ifield Steam Mill; Burgess Hill Pug Mill.
 No.33 (2003) H.A. Waller & Sons; Electrical Generation at High Salvington; C.V.A./Kearney & Trecker; Cocking Lime Works; Nutley Windmill; Longleys at Christs Hospital.
 No.34 (2004) West Sussex Brewers; Swanbourne Pumphouse; Hammond Family and Mills; Shoreham Cement Works; Pullinger's Registered Designs; Balcombe Road Forge, Crawley.
 No.35 (2005) Halsted & Sons of Chichester; Swanbourne Pump House, Arundel; Concrete Shipbuilding at Shoreham; Turnpike Roads to Chichester, Petworth and Midhurst
 No. 36 (2006) The British Syphon Company; Turnpike Roads to Arundel, Worthing and Littlehampton; Brewers of East Sussex; West Hill Cliff Railway, Hastings—Engine Room; The Lamp Posts of Ditchling.
 No. 37 (2007) Poynings Mills; Lavington Park Pump House; Tollhouse and Milestone Survey; A Colonel Stephens 'Find'; CVA Eaton Road, Hove; Cowfold and Henfield Turnpike (Part 1)

Issues 2, 3 and 5 £1 each, issue 17 £1.50, issues 19, 21 and 22 £2.25 each, issues 23 and 24 £2.50 each, issues 25 and 26 £2.75 each, issues 27 and 28 £2.95 each, issues 29, 30, 32, 33 and 34 £3.95 each, issues 35, 36 and 37 £4.25 each. Post and packing extra, 80p for one copy plus 50p for each subsequent copy. For a list of the articles in volumes no longer available for sale see *Sussex Industrial History* 25 (1995). The Honorary Secretary is prepared to quote for photocopying articles in these issues.

Also available:-

- M. Beswick, *Brickmaking in Sussex* (revised edn 2001) £12.95 post free
 F. Gregory, *A Sussex Water Mill Sketchbook* £6.95 post free
 H. T. Dawes, *The Windmills and Millers of Brighton* (2nd edn.) £4.95 (£5.50 incl. post and packing)
 Alan H. J. Green, *The History of Chichester's Canal* £6.50 (£7.50 incl. post & packing)

Orders with remittance to:-

R.G. Martin, 42 Falmer Avenue, Saltdean, Brighton BN2 8FG Tel. 01273 271330

Tamplins Brewery Office, Brighton

(Photo: Peter Holtham)



Black Lion Brewery, Brighton

(Photo: Peter Holtham)

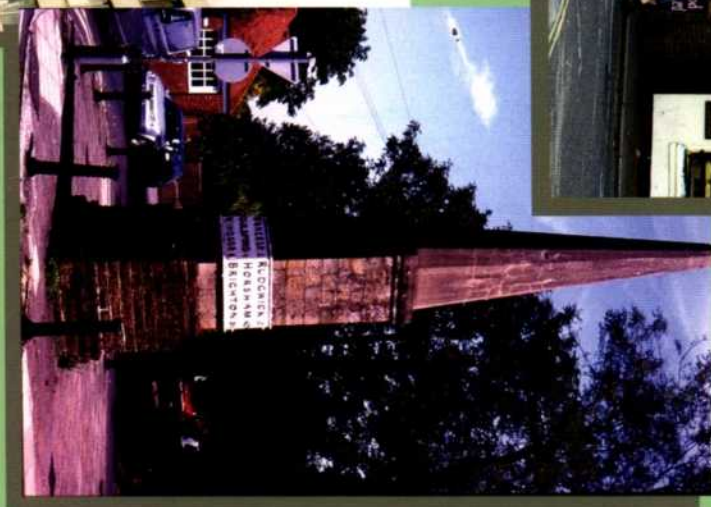

Obelisk at Cranleigh, Surrey c1830

(Photo: Brian Austen)



Milestone with cast-iron plate at Capel

(Photo: Brian Austen)